

Department of the Army  
Headquarters, U.S. Army Cadet Command  
1st Cavalry Regiment Road  
Fort Knox, Kentucky 40121-5123

USACC Circular 145-05

Effective 01 February 2022

---

**CADET SUMMER TRAINING**

---

FOR THE COMMANDER:

OFFICIAL:

JOHNNY K. DAVIS  
Major General, U.S. Army  
Commanding



MAURICE O. BARNETT  
COL, AD  
Commandant

**History.** This publication is an annual update that impacts the training process of U.S. Army Cadet Command Cadet Summer Training (CST).

**Applicability.** This circular is applicable to all Cadets and cadre attending CST at Fort Knox, Kentucky (FKKY).

**Proponent and Exception Authority.** The proponent for this circular is the USACC G37. The proponent has the authority to approve exceptions or waivers to this circular which are consistent with controlling laws, regulations, and USACC policies. Activities may request a waiver to this circular by providing justification including a full analysis of the expected benefits and must include formal review by the activity's senior legal officer. All waiver requests will be endorsed by the commander or senior leader of the requesting activity and forwarded through their higher headquarters to the policy proponent.

**Army Management Control Process.** This circular does not contain management control provisions.

**Supplementation.** Supplementation of this circular and establishment of local forms are prohibited by subordinate commands of USACC.

USACC CIRCULAR 145-5, 12 October 2021

---

**USACC CIRCULAR 145-05**

# **CADET SUMMER TRAINING**

**12 October 2021**

---

**DISTRIBUTION RESTRICTION: Approved for public release; distribution is unlimited.**

**UNITED STATES ARMY CADET COMMAND**

---

---

## **Summary of Changes**

- Corrected verbiage for linen draw from G4.
- Provided guidance on Cadet pay and management.
- Specified requirements for advanced camp graduation.
- Specified on completing advanced camp evaluation report.
- Provided guidance on essential unit messing for cadre.
- Provided guidance on hand carrying CST required documents.
- Provided COVID guidance.
- Deleted CCWP chapter.
- Removed COVID Exposure Flowcharts

---

**Suggested Improvements.** Send comments and suggested improvements on **DA Form 2028 (Recommended Changes to Publications and Blank Forms)** to Headquarters, G3, U.S. Army Cadet Command, Fort Knox, Kentucky 40121.

**Distribution.** Distribution of this circular is intended for USACC Headquarters, Brigades and Detachments, and to all supporting agencies to include TRADOC, USARC, FORSCOM, MEDDAC, Soldiers, Civilians, Contractors and Interns assigned to CST. This Document is posted to the HQ, Cadet Command Knowledge Management sites.

---

---

## TABLE OF CONTENTS

<b>Chapter 1 - Introduction</b> .....	<b>6</b>
<b>1-1. Purpose</b> .....	<b>6</b>
<b>1-2. References</b> .....	<b>6</b>
<b>1-3. Explanation of Terms</b> .....	<b>6</b>
<b>1-4. Responsibilities</b> .....	<b>6</b>
<b>1-5. General</b> .....	<b>6</b>
<b>1-6. Mission</b> .....	<b>7</b>
<b>1-7. Key Tasks</b> .....	<b>8</b>
<b>1-8. Endstate</b> .....	<b>9</b>
<b>Chapter 2 – Cadet Summer Training (General)</b> .....	<b>10</b>
<b>2-1. Cadet Information</b> .....	<b>10</b>
<b>2-2 General Administrative Information</b> .....	<b>19</b>
<b>Chapter 3 – Basic Camp (BC)</b> .....	<b>28</b>
<b>3-1. Overview</b> .....	<b>28</b>
<b>3-2. Cadet Information</b> .....	<b>29</b>
<b>3-3. Detachment Administrative and Logistical Preparation of Cadets</b> .....	<b>31</b>
<b>3-4. Basic Camp Cadet Evaluation</b> .....	<b>33</b>
<b>Chapter 4 – Advanced Camp (AC)</b> .....	<b>35</b>
<b>4-1. Overview</b> .....	<b>35</b>
<b>4-2. Cadet Information</b> .....	<b>36</b>
<b>4-3. Detachment Administrative and Logistical Preparation of Cadets</b> .....	<b>37</b>
<b>Chapter 5 – Cadre Guidance</b> .....	<b>44</b>
<b>5-1. General Administrative Information</b> .....	<b>44</b>
<b>5-2. Common to Cadre– General Information</b> .....	<b>52</b>
<b>5-3. Safety</b> .....	<b>74</b>
<b>APPENDIX A – References</b> .....	<b>76</b>
<b>APPENDIX A-1. Glossary</b> .....	<b>79</b>
<b>APPENDIX B CST TASK ORG</b> .....	<b>84</b>

<b>APPENDIX C Cadet Record Items .....</b>	<b>93</b>
<b>CST CADET PERSONNEL RECORDS CHECKLIST .....</b>	<b>86</b>
<b>CONSENT FOR MEDICAL AND DENTAL CARE OF MINOR.....</b>	<b>87</b>
<b>MEDICAL POWER OF ATTORNEY .....</b>	<b>87</b>
<b>APPENDIX D - CST Medical Records .....</b>	<b>89</b>
<b>APPENDIX E – Cadre In-Processing Checklists .....</b>	<b>97</b>
<b>APPENDIX F – POV Storage SOP.....</b>	<b>100</b>
<b>APPENDIX G – Remediation for Advanced Camp Credit.....</b>	<b>100</b>

**TABLES**

<b>Table 1 – Typical Training Day .....</b>	<b>29</b>
---	-----------

**FIGURES**

<b>Figure 1-D. CST Cadet Personnel Record Checklist</b>	<b>86</b>
<b>Figure 2-D. Consent for Medical and Dental Care of Minor</b>	<b>88</b>
<b>Figure 3-E. CST Medical Record Checklist</b>	<b>99</b>
<b>Figure 4-E. Cadet Mini-Registration</b>	<b>92</b>
<b>Figure 5-E. Example of DD Form 2005</b>	<b>93</b>
<b>Figure 6-E. Safe to Train Physical</b>	<b>94</b>
<b>Figure 7-E. Safe to Train Physical (continued)</b>	<b>95</b>
<b>Figure 8-E. Flight Physical Request</b>	<b>96</b>
<b>Figure 9-F. Cadre In-Processing Checklist</b>	<b>97</b>
<b>Figure 10-F. 2LT In-Processing Checklist</b>	<b>98</b>
<b>Figure 11-F. 2LT Uniform Allowance Statement</b>	<b>107</b>
<b>Figure 12-G. Cadet POV Registration Form HFL Form 45 (Front)</b>	<b>103</b>
<b>Figure 12-G. Cadet POV Registration Form HFL Form 45 (Back</b>	<b>104</b>
<b>Figure 13-G. Cadet POV Inspection Form FKKY Form 4860</b>	<b>105</b>
<b>Figure 14-G. Cadet POV Storage Checklist</b>	<b>106</b>

---

## **Chapter 1 - Introduction**

### **1-1. Purpose**

To provide administrative instructions for the arrival and departure of Cadets and Cadre to Cadet Summer Training (CST).

### **1-2. References**

References are listed in Appendix A.

### **1-3. Explanation of Terms**

Acronyms and special terms are defined throughout the document as they are used.

### **1-4. Responsibilities**

a. In the event of a conflict between any provision of this circular and any applicable Army Regulations (ARs), rule, policy or law, AR 145-1 applies unless a more specifically applicable AR, rule, policy, or law is found to be more applicable. In such an event, consult with the USACC Staff Judge Advocate (SJA) office for a legal opinion before proceeding and they will provide a written legal opinion on the best course of action.

b. Key Command and Staff leadership are noted in Appendix B- CST Organization Chart.

### **1-5. General**

a. USACC executes CST at Fort Knox, Kentucky (FKKY). There are four (4) components to CST; (1) Basic Camp (BC), (2) Advanced Camp (AC), (3) Cadet Professional Development Training (CPDT), (4) 2LT Development. All personnel training or supporting CST will be fully vaccinated against COVID-19 prior to reporting to Fort Knox, KY.

b. BC is a primary basic military skills training course and a 2-year commissioning lateral entry program. Through BC, students without Military Science Basic Course experience earn credit for the course. It is often a prospective Cadet's first exposure to

USACC CIRCULAR 145-5, 12 October 2021

---

Army life on an Army installation and one of the few opportunities where Cadets from various parts of the country undergo a common, high-quality training experience.

c. The AC mission is to train Cadets, develop Cadet leadership, and provide feedback for individual officer development. AC is intentionally stressful and is designed to build individual confidence through the accomplishment of tough and demanding training. The course is designed to build upon the core on-campus instruction by developing and assessing leadership potential in a platoon-level environment.

d. The Cadet Professional Development Training (CPDT) programs encompass a variety of leader development and training opportunities for Cadets. These opportunities include the Cadet Troop Leader Training (CTLT), Internships, and Cadet Advanced Individual Training (CAIT) programs. These programs offer leader training and development as well as attendance at duty skill enhancement schools and specialized training courses. Cadets must be contracted to be eligible for any CPDT opportunity. Once a Cadet accepts a CPDT assignment, it becomes a commissioning requirement IAW Army Directive 2015-15 (Professional Development Training for Senior ROTC Cadets, 18 March 2015)

(1) Cadets dismissed from Advanced Camp will lose their CTLT assignments, IAW Cadet Command Regulation 145-03-1, which states successful completion of Advanced Camp is a non-waiverable prerequisite for CTLT assignments.

(a) Physical assessment or height/weight failure will cancel all CPDT assignments.

(b) Training event failure will cancel CTLT assignments, but retain leader/mentor assignments (as remediation).

(2) Eligibility of Green To Gold Active Duty Option to attend CPDT assignments is governed by USACC Regulation 145-6.

## **1-6. Mission**

The Cadet Command mission is to commission the future officer leadership of the U.S. Army and motivate young people to be better citizens. Within this framework, the BC,



---

AC, and missions are to **TRAIN** Cadets to Army standards, **DEVELOP** leadership, and **ASSESS** officer leadership potential.

### **1-7. Key Tasks**

a. Train competent and confident Second Lieutenants for the U.S. Army through challenging CST programs that are based upon Senior ROTC outcomes and goals.

b. Develop the training and education program for all cadre (USACC, FORSCOM, and USAR) to prepare master training mentors enabled to guide Cadet development within the USACC developmental model.

c. Train Advanced Camp Cadets by the following guidance:

(1) Prove physical preparedness to continue Advanced Camp.

(2) Demonstrate competence in Basis Officer Leadership Course (BOLC-A) tasks, squad tactics, and RECONDO training, to include OPAT, Land Nav, Basic Rifle Marksmanship (BRM), 12-mile foot march, Confidence, First Aid, and CBRN.

(3) Cadet leadership opportunities are of paramount importance and the number one priority in the AC Field training exercise (FTX), through which Cadets demonstrate their leadership abilities and competence in field craft.

(4) Cadets value reflection, counseling, and mentorship during the recovery phase to inspire professional growth, promote lifelong learning, and become stewards of the profession.

(5) Continuity of the Camp program without any holiday interruptions.

d. Train Basic Camp Cadets by the following guidance:

(1) Execute a training program as a basic training-like experience including: drill and ceremonies, customs and courtesies, Physical Readiness Training (PRT), BRM, individual skills.

(2) Integrate Drill Sergeants (DS) per Platoon.

(3) Evaluate and highlight propensity to serve.

---

## **1-8. Endstate**

- a. CST is safely executed, including all Cadre and Cadets return to campus and be ready for the academic year.
- b. CST outcomes are achieved: AC Cadets have improved leadership attributes and competencies on a developmental glide path to successful commissioning; Basic Camps Cadets show improved capability and skill in Warrior Tasks and Battle Drill and are become prepared for continued progression in ROTC.
- c. Cadre development broadened and improve abilities of leaders to develop leaders, understand training management, and become sought after by the operational force.
- d. Future CST concepts and planning in-progress during current CST.
- e. Command, control, and supporting programs continue to mature to enable and expanded Basic Course Cadet load. As well as providing CPDT Cadets, leader enrichment programs which expose Cadets to military skills, international cultures, and additional leader development opportunities.

---

## **Chapter 2 – Cadet Summer Training (General)**

### **2-1. Cadet Information**

#### **a. Travel Arrangements/Administrative Preparation**

(1) Cadet travel authorizations and vouchers are completed by using the Defense Travel System (DTS). Organization Defense Travel Administrator (ODTA)/Non-DTS Entry Agent (NDEA) at each Detachment, typically the Program HRA, will complete round-trip travel arrangements on behalf of the Cadet.

(2) Cadet's DTS Profile General Traveler Data Civilian/Military should be set to "E-Entlisted"; Title/Rank to "MC-00". Ensure Active/Reserve Category is "V-Reserve;" Military Branch of Service is "US Army;" and Reserve Code is "PJ-Ready Reserve Training. Individual in "Officer Training Program" prior to creating travel authorizations. The Trip Type for all Cadet travel authorizations will be "AA-Routine TDY/TAD."

(3) Cadets are authorized travel allowances in accordance with (IAW) JTR Chapter 3, Paragraph 032402 SROTC Member, Section B Table 3-11 and the Assistant Secretary of the Army (Manpower and Reserve Affairs) decision rendered in 53 Comp. Gen. 957 (1974).

(4) Scholarship Cadets attending CST are authorized travel day per diem meals and incidentals for non-travel days in accordance with the CST Exception. The CST Exception states that scholarship Cadets attending CST whose related stipend DOES NOT begin prior to their CST start date are considered as non-scholarship Cadets for CST related travel purposes and therefore are not authorized travel day per diem meals and incidentals for non-travel days.

(5) Continue to create authorization in accordance with Cadet Command Cadet Travel Handbook.

(6) Cadets may only travel to or from their Home of Record (HOR), Educational Institution, or Follow-on Training assignment location. HOR must not be changed to accommodate travel to or from non-ROTC internships or personal travel requests.

(7) Cadets are not authorized to change Centrally Billed Account (CBA) tickets. CST DTS Cell will make all CBA ticket changes on a case by case basis using the contracted CTO. Per the JTR, any TDY travel changes for personal convenience are not authorized and at the expense of the traveler.

---

(8) Non-DTS Entry Agents (NDEAs) must confirm Cadet airline reservations are ticketed NLT 72 hours prior to the Cadet's departure date (the DTS system will generate two separate emails, the first will be with the Itinerary and the second will be Official Ticketed Invoice). If no confirmed Official Ticketed Invoice is sent 72 hours prior to the departure date, the NDEA must immediately contact the Fort Knox Carlson Wagonlit Commercial Travel Office (CTO) office (1-800-296-2989) directly to resolve the problem.

(a) At a minimum, NDEAs should run the Pending Airline Cancellation Report within the DTS Report Scheduler at the beginning of each week and mid-week to ensure all travelers have confirmed ticketed reservations. The Pending Airline Cancellation Report provides a list of travel authorizations containing airline reservations that require routing action (e.g., REVIEWED and APPROVED) to prevent the cancellation of airline reservations. Authorizations that have not been approved will not ticket.

(b) If reservations have not been ticketed, NDEAs should perform the required routing actions (i.e., sign the authorization if pending signature, contact your BDE POC if pending approval). An approved travel document is required for CTO to ticket airline reservations. If the travel authorization is not approved within 72 hours of departure, CTO will cancel reservations automatically.

(9) Retain and safeguard all copies of tickets and orders. Cadets must furnish all transportation documents upon in-processing to CST.

(10) All flight reservation changes for Cadets returning to HOR/school after CST will be arranged prior to Cadet's departure to FKKY. Cadet return travel can only be scheduled to their HOR, ROTC School, or Follow-on training assignment. No other destinations are authorized. IAW JTR Chapter 2, Para 020206,M,1,a - City Pair Program fares (Government Contracted Airfare) are for official travel only and cannot be used for travel to or from vacation points or for any portion of a route traveled for personal convenience. **Return flights to depart Louisville International Airport should be scheduled not earlier than (NET) 1500 on graduation day.** During training, return travel arrangements will only be changed for Cadets as mission requires and not for Cadet convenience.

(11) Cadets with seven or fewer days between consecutive training assignments must be scheduled to remain at Fort Knox between training dates. Whenever possible, Cadet training should be scheduled to minimize required travel between assignments.

(a) Cadets with greater than seven days between training assignments must be scheduled to return home prior to follow-on training.

(b) Cadets must report to initial training assignment with equipment required to complete all required training.

(c) Active Duty for Training orders for Cadets remaining at CST between training assignments will be amended by CST G1 team.

(12) Cadets departing CST should NOT make critical personal plans for the day following completion of CST. Historically, scheduling changes and other travel issues (i.e., unticketed reservations) have caused unexpected delays in Cadet Travel, delaying arrival at their next destination (HOR/School).

(13) End-of-Camp commissioning ceremonies will not be conducted by CST personnel. Should a program or Brigade wish to commission a Cadet at the conclusion of his/her training, the program will be responsible for all coordination and preparations associated with the commissioning. Departure travel must be scheduled to depart on the same day as the 2LT commissions, as Cadet orders must be amended to end upon commissioning.

(14) Privately Owned Vehicle/Government Owned Vehicle (POV/GOV) Travel. The authorized mode of transportation for Cadet Travel is Government Contracted Airfare.

(a) There are no vehicle storage facilities available for Cadets while they are at Follow-on training. Therefore, Cadets with follow on training should not travel via POV.

(b) Cadets authorized by their PMS to travel to CST by POV must be the owner/operator of such vehicle and follow the instructions below:

(1) Valid insurance card. Vehicles must be validly registered and insured in accordance with state law.

(2) Valid state registration. If the Cadet is not the legal or registered owner, a notarized statement from the owner of the vehicle must be presented, which gives the Cadet permission to drive the vehicle.

(3) Valid state driver's license. Cadets must maintain and be prepared to present a valid driver's license.

(i) Access to Fort Knox: FKKY main gate is located at Bullion Blvd Exit on Dixie Hwy 31W. Fort Knox employs an Automated Installation Entry (AIE) System as well as employing the REAL- ID Act requirements. These processes require all personnel possessing a Common Access Card (CAC) accessing Fort Knox to register in the AIE system to gain entry to the installation. Additionally, all personnel not in possession of a valid CAC entering the installation must possess a valid and current picture identification (i.e, driver's license, passport) issued by a government agency such as a state, federal, or foreign government. Those who are still uncertain whether they have the proper identification to enter Fort Knox should call (502) 624-7014/1713. Proper identification must be presented at the gate in order to gain access. All drivers must ensure their vehicle is properly registered and insured. Frequent inspections of these documents are conducted by security personnel. Fort Knox is a secure post; people and vehicles are subject to inspection at any time while within the boundaries of the military reservation. All personnel not previously registered to access Fort Knox must stop at the Visitor's Center at the Main Gate for access.

(ii) Cadets driving POV must report to BLDG 6590, at 48 Daniel Boone Street Fort Knox, KY 40121, no later than 1700 on their scheduled report date. Failure to report on time may cause a Cadet to miss important reception and integration tasks.

(15) All Cadet Travel must be entered into CCIMM in the training module. Travel inputs must include mode of travel, arrival times, and travel details for each leg of the training, to include training prior to or following CST at Fort Knox.

**NOTE:** When POV travel is authorized, for travel over 400 miles one-way or 800 miles round-trip, reimbursement is limited to the cost of Government Contracted airfare or the cost of mileage (whichever is most advantageous to Government). A Constructed Travel Worksheet (CTW) is required and must be uploaded in the DTS authorization for travel over 400 miles one-way or 800 miles round-trip. For distances for trips under 400 miles one-way or 800 miles round-trip, CTWs are not required and cost of mileage will be reimbursed.

b. Reporting to CST.

(1) It is imperative that Cadets be scheduled to arrive NLT 1700 (Eastern Time) on their designated arrival date. Appropriate civilian attire while traveling is authorized.

---

Appropriate civilian attire is defined as that which meets common sense standards of safety, decency, and neatness. Soldiers are associated and identified with the U.S. Army in and out of uniform and when on or off duty. Therefore, when civilian clothing is worn, Cadets will ensure that their dress and personal appearance are conservative and commensurate with the high standards traditionally associated with the U.S. Army. Cadets must be prepared to move quickly and comfortably upon arrival to Fort Knox. Many of the inprocessing requirements will occur outside and will require bending, lifting, and walking fast.

(2) Directions to FKKY can be found on the Fort Knox website located at <http://www.knox.army.mil>.

(3) Cadets should travel with enough money (~\$40.00) to pay for meals on travel days.

(4) Louisville International Airport (SDF) Information: Commercial airline flights to the FKKY area arrive at SDF, located in the southern part of suburban Louisville, approximately 45 minutes north of Fort Knox. Upon arrival, all Cadets should claim baggage and report to the CST Assistance Desk located at Baggage Carousel E on the bottom floor on the airport. At this location, Cadets will be directed to designated ground transportation to FKKY. Uniformed personnel will be available till 2200 throughout the airport on arrival days to assist Cadets.

(a) Cadets arriving at SDF outside of directed hours are to report to the Louisville International Airport USO Lounge, located on the airport's ticketing level. Ground transportation to FKKY will be arranged by CST Staff at that location.

(b) Baggage. Check airlines for baggage limitations prior to arrival at the origin airport to determine charges for additional baggage (if reimbursement for baggage fees will be requested, the Cadet will need to furnish all receipts to the NDEA). Government items identified in APP C (CST Cadet Checklists) are considered to be at least one of the regular bags. TSA regulations require that all items must be secured inside bags. Any locks on bags may be cut by TSA. Additional bags are excess and are NOT reimbursable. International Program managers will issue specific guidance to Cadets traveling overseas. CST does not have a funds account to pay for baggage fees. Cadets will need to pay for baggage fees upfront, reimbursement will occur after DTS vouchers are processed.

---

(5) All Cadets travelling by POV/GOV must report to building 6590, Copple Center, (48 Daniel Boone Street, Fort Knox, KY 40121) in appropriate civilian attire, NLT 1700 on the scheduled arrival day. Failure to report on time can result in transfer to a subsequent cycle. Upon arrival at CST, Cadre will designate Cadets to park POVs in a secure designated lot with no overhead cover and will not be allowed to drive or access the vehicles until the day they depart FKKY.

(a) Security of Vehicles. While at CST, lock all vehicles when parked. Do not leave valuables in parked vehicles. Recommend hubcaps, antennas, or other easily removable items be secured in the trunk.

(b) Cadet privately owned vehicle (POV) storage (See APP G)

(c) The G4 transportation motor pool will control access to the POV Lot.

(d) Task Forces (TF) Warrior and Leader have the overall responsibility for Cadet POV storage.

c. Cadet Records Receipt. Need to refine once IPPS-A goes live. Cadets may need to be directed to have updated DD93 in IPPS-A prior to reporting for Camp

(1) All Cadet Personnel Records, IAW Appendix D, will be hand-carried to FKKY by the attending Cadet and should not be placed in checked baggage.

(a) Programs MUST retain a copy of all records sent to CST for Cadet training. Requests for early release from a Regiment will be approved by Regimental Task Force Commander, and approval will be based on circumstances, completed training and eligibility for camp credit. Cadets should be scheduled to attend Regiments that do not require early release. Programs MUST ensure Cadets' records are updated in the CCIMM Student Management and Training Modules.

(2) All Cadet Medical Records IAW APP E, must be scanned to the following: [https://ccimm.usacc.army.mil/psp/ccimm/EMPLOYEE/PT\\_LOCAL/h/?tab=DEFAULT](https://ccimm.usacc.army.mil/psp/ccimm/EMPLOYEE/PT_LOCAL/h/?tab=DEFAULT)

(3) Incomplete or missing records can delay a Cadet's medical examination/qualification at CST, delay notification of Next of Kin (NOK) in the case of serious illness/injury, or have an adverse impact on other Cadet Personnel actions.

d. What to Bring to CST. See Appendix C.



---

e. **Mandatory Items.** Cadets must bring all documents and items listed on the Cadet Clothing & Equipment Checklist.

f. **In processing procedures.** Timing of the following is typical; however, availability of medical staff for physicals may change some regiments' in-processing schedules. (Check Regimental Training Schedule for specifics.)

(1) **Items to have on hand and prohibited items.**

(a) **Shakedown Inspection** must be conducted on Day-0. Cadre are not authorized to remove/prohibit any Cadet items listed as "required" or "recommended" items.

(b) **Cell Phones.** Cadets will be allowed to retain cell phones for use after the duty day in garrison only. Cadet cell phone use will be managed by CST cadre.

(c) **Medications.**

i. All medications must be in the original labeled container (over the counter or prescription, to include birth control pills) prescribing the medication. Medical cadre members may, to protect health and welfare, inspect the contents of any open bottle of medication to ascertain the pills are all the same and consistent with the labeled contents.

ii. Category III and IV controlled substances will be reviewed by medical cadre to ensure there is a valid prescription.

iii. **Over-the-counter (OTC) medications.** OTC medications for pain or allergies will remain with Cadets for ongoing use as intended and approved by the Food and Drug Administration (FDA); however, Cadets should be aware of the potential for the medication to mask symptoms of disease or injury. If the Cadet is taking the maximum daily recommended dose, the Cadet should inform cadre to discuss the need to be seen at the clinic. The major side effects of OTC allergy preparations are drowsiness and dehydration, both of which are dangerous in a field/training environment. Cadets concerned about allergies in the field environment should discuss this with the physician during their medical examination at CST.

iv. **Metabolic enhancers, stimulants, and creatine supplements of ANY kind** are prohibited and will be stored for the duration of CST. You may bring healthy non-

perishable, pre-packaged snacks such as protein bars with you to Fort Knox. There will also be time and facilities available for local purchase.

v. All medications must be declared on DA Form 2807-1. Prescription medications will remain in the Cadet's control at all times.

vi. Sharing of prescription drugs between individuals is illegal under both Kentucky state law and federal law. Cadets who share prescription medications may be subject to administrative or legal action.

vii. There is no list of recommended OTC drugs; however, Cadet's should bring any OTC drugs they are currently taking and should consider a supply of "normal" OTC type drugs (e.g., Aspirin).

(2) Prohibited Items. Cadets possessing any of the prohibited items listed below will have the item confiscated and reported to the CST Chain of Command:

i. Weapons or ammunition of ANY type. No knives with blades longer than three (3) inches. Disposition of confiscated weapons and/or ammunition will be determined by the appropriate authorities.

ii. Pornography. Pornography will be destroyed..

(3) Unauthorized Items. (Stored until completion of CST)

i. Expensive watches or jewelry valued over \$150.

ii. Controlled substances, to include tobacco or alcoholic beverages of any type.

iii. Tanker Boots, zipper boots, and all cold weather boots will be confiscated and stored until completion of CST.

iv. Large amounts of cash (in excess of \$500).

v. Contact Lenses.

(4) The Cadet will receive an inventory and receipt for high dollar items to be stored. Only cadre are permitted access to stored items throughout CST.

g. Inprocessing Day 1-Day 3.

(1) Refer to CST Standard Operating Procedures (SOP), Appendix E Medical, for Cadet Physical Exam process.

(2) Cadet height/weight will be conducted at the regimental area by the regimental cadre.

(3) All Cadets will be provided access to medical treatment facilities. Cadets currently covered by TRICARE as dependents must be counseled on the ramifications of changing their Defense Enrollment Eligibility Reporting System (DEERS) Status. TRICARE will not cover any medical expenses for treatment received while a Cadet is in official ROTC training except for Green to Gold Cadets. They should expect to revalidate DEERS status at the expiration of their Active Duty orders.

(a) All medical bills for Cadets and Designated Applicants (except Active Duty Orders (ADOs)) will be processed through Department of Labor for payment. After claims have been submitted, Cadets will be required to provide copies of any bills and/or written communications with Department of Labor to ROTC program for processing through HQ, USACC G1 and Surgeon.

(4) Cadets will bring ID, shot records, all medications, any medical records not uploaded into medical sharepoint, and wet weather bag with them to physical. RTO call on uniform- based on weather.

(a) All Cadets will complete the medical forms outlined in APP E for inclusion in the Cadet Medical Record. Cadets must provide accurate information and documentation about previous illness/injury and medications taken. Concealment of a medical condition or medications used can lead to disenrollment from the ROTC program.

(b) All medications, both OTC and prescription, must be in their original containers.

## 2. Medical & Dental Care, Benefits, & Claims at CST.

(1) Medical Care. Nelson Troop Medical Clinic (TMC), TAA Baker Role 2 Medical Clinic and TAA Densberger Role 1 Forward Aid Station will provide immediate medical care for injuries and illness incurred during CST. Sick call is provided daily in garrison and field environments during CST.

(2) Medical or dental conditions that occur during CST which are likely to require further treatment will be processed via a medical claim with the Department of Labor.

(3) Dental Care will be provided for dental emergencies only at Jordan Dental Clinic FKKY.

(4) All Cadets (except ADOs) who receive treatment outside of a Military Medical Facility will require a medical claim through Department of Labor for payment of all medical bills. Should a claim not be initiated and filed during CST, ROTC program staff will be responsible for filing claim and assisting Cadet with required claim submission and follow-up.

b. Departure from CST.

(1) Cadets may depart Fort Knox after the conclusion of the graduation ceremony, once released by their regiment. All Cadets should expect to have some administrative tasks to complete after graduation. Do not schedule personal events or plan for departure immediately (~2 Hours) following graduation or commissioning ceremonies. Task Force Commanders may delay departure for Cadets who are subject to on-going investigations or pending disenrollment board actions.

(2) Return flights to depart Louisville International Airport should be scheduled not earlier than (NET) 1500 on graduation day due to time and logistical constraints on Cadet Transportation and security requirements at the airport. Any required flight changes for Cadets training at Fort Knox will be made by CST G1 staff. Flight changes for Cadets not at Fort Knox for training must be coordinated through ROTC program staff.

## **2-2 General Administrative Information**

a. Basic Physical Conditioning.

(1) General. CST demands a high level of physical fitness. Cadets will have difficulty keeping pace with the physical training program unless they are in good physical condition upon arrival.

(2) Preparation.

(a) Cadets should already have a personal program of conditioning or should start one immediately and continue a physical fitness program until reporting to CST.

---

USACC cadre members are a good source of assistance if help is needed developing a physical fitness plan.

(b) Throughout CST, Cadets will foot march from 1 to 12 miles. Cadets are discouraged from obtaining pedicures prior to CST as pedicures remove calluses and make feet more susceptible to blisters. Cadets should gradually wear the combat boots they will wear during CST to break them in and avoid foot injuries during training. Blisters continue to be a problem with Cadets. The more Cadets wear boots prior to attending CST, the better prepared they are. Condition Cadets in preparation for extended foot marches.

(c) Daily physical readiness training. While at CST, Cadets sustain their physical conditioning through participation in scheduled physical readiness training (PRT) sessions and physically demanding training.

b. Discipline.

(1) Cadets will conduct themselves in a manner befitting a future commissioned officer. Cadets displaying poor attitudes, poor behavior, or substandard performance warranting disciplinary action may be subject to evaluation by a board of officers and possible dismissal by the CST Commandant. This standard applies while traveling to and from CST.

(2) Contracted Cadets will all be on Title 10 orders for active duty training while attending CST and are subject to Uniform Code of Military Justice (UCMJ). Student-attendees are considered "designated applicants" and are therefore NOT subject to UCMJ, but could be sent home for disciplinary infractions.

(3) Policy Letters, to include off-limits areas, are not included in CC CIR 145-05. Policy letters will be posted in common areas throughout CST.

(4) Alcohol consumption by Cadets is prohibited during CST unless specifically approved by the Commanding General during social events or celebrations. During these events and celebrations, limits will be strictly enforced on Cadet alcohol consumption levels. Cadets who violate alcohol consumption level restrictions or provide alcohol to unauthorized Cadets are subject to dismissal from training and other administrative actions as appropriate.

(5) Sexual activities are prohibited during CST.

(6) Sexual harassment, improper relationships, and fraternization will not be tolerated and will be dealt with expeditiously. SHARP and EO personnel will be on staff throughout CST to assist with any Cadet EO or sexual harassment issues. AR 600-20 outlines the Army's SHARP and EO programs.

(7) Sexual assault and sexual harassment are crimes under the UCMJ and appropriate legal actions will be taken.

(8) Family and Visitors. Family members are NOT authorized to attend CST or visit Cadets during CST.

c. Post Exchange (PX).

(1) Due to the compressed schedule and limited personal time, Cadets should plan on having limited access to the PX and should pack personal care items accordingly.

(2) Each Regiment will have pre-scheduled appointments to visit the Disney Area Troop Store. The Troop Store carries toiletries, magazines and books, towels, etc. The Fort Knox Main PX is comparable to a department store, but access must be coordinated through the PTO/PTNCO and is not normally available.

(3) Dress regulations are strictly enforced. The Operational Camouflage Pattern (OCP) is permitted in PX facilities. The Improved Physical Fitness Uniform (IPFU) change to read: Army Physical Fitness Uniform (APFU) is not authorized for wear in the PX.

(4) Debit/Credit Cards will be accepted at the facilities. Cadets may cash personal first-party checks for not more than \$20 over amount of purchase if desired. Cadets will speed check cashing times if the following information is already printed on the front of their check: Name; University; City & State; Regiment at CST.

(5) Each Regiment will have pre-scheduled appointments to visit the barber shop during training. Please ensure Cadets have adequate cash (~\$15.00) to pay for basic barber services. Cadets are required to remain in compliance with hairstyles IAW AR 670-1.

d. Postal Services.

(1) Cadets should bring an initial supply of stamps, writing paper, and envelopes to CST. The Disney Area Troop Store does sell stamps. Complete postal services are available at the Fort Knox Main Post Office, but access is extremely limited for Cadets during CST.

(2) Mailboxes for outgoing mail are located throughout the CST area. All outgoing mail should include the CST address as the return address.

(3) Cadets can sign up to use Sandboxx, an approved private business application that offers overnight mail services, the ability to send AAFES gift cards, and a way for family members to receive updates of their Cadet's training schedules and graduation events. For more information visit: <https://www.sandboxx.us/>

(a) To send mail to Basic Camp Cadets, use the following address format:

**CADET LAST NAME, FIRST NAME MI  
HQ, USACC, BC  
XX REGT, XX COMPANY, XX PLATOON (specify)  
24 RHINELAND STREET  
FORT KNOX KY 40121-5117**

(b) To send mail to Advanced Camp Cadets, use the following address format:

**CADET LAST NAME, FIRST NAME MI  
HQ, USACC, AC  
XX REGT, XX COMPANY, XX PLATOON (specify)  
24 RHINELAND STREET  
FORT KNOX KY 40121-5117**

e. Pay and Subsistence.

(1) Direct Deposit/Electronic Fund Transfer (EFT).

(a) All Cadets attending CST must have either a checking or savings account established prior to being entered into the CCIMM Training Module and DTS profile. Direct Deposit/EFT is mandatory for all CST attendees. Detachments must enter the following Direct Deposit/EFT information into the CCIMM Training Module and the Cadet DTS profile:

i. Type Account (Checking or Savings)

---

ii. Accurate and current 9-Digit Transit Routing Number

iii. Accurate and current account number

(b) POC for Direct Deposit/EFT is Chief, Pay Operations Division, G8, 502-624-6129, DSN 464-6129.

(2) Cadets in a current pay status will be paid on the 1st and 15th of the month by EFT. Cadet pay will be deposited directly into the same account as the monthly stipend checks are deposited.

(3) Family Separation. Green to Gold Active Duty (GTG-AD) Cadets who have dependents living with them are authorized Family Separation Allowance only if they successfully complete a minimum of 30 continuous days at AC. Once GTG-AD Cadets have returned to their home station, they will file a travel voucher through their ROTC Detachment. Upon payment of the travel voucher and receipt of the settlement voucher/notification, GTG-AD Cadets will submit DD Form 1561 with a copy of the settlement voucher/notification to the Fort Jackson Student Detachment which will process the pay adjustment. Expect this process to take 1-3 months. GTG-AD End of Course Commissionees (EOCCs) are also entitled to this allowance.

(4) BC Cadets.

(a) May elect to receive a one-time \$50.00 cash advance during in-processing.

(b) Base pay starts on Day 1 of BC. Cadets will be paid in accordance with DODFMR and Army Regulation 37-104-4 at a rate as published by Defense Finance and Accounting Service (DFAS). Cadet pay is subject to applicable state and federal taxes.

(c) During BC, Cadet Pay questions should be addressed through the Regimental HRA for resolution. Following BC, Cadet Pay questions should be addressed to the Battalion Human Resource Administrator (HRA).

(5) AC Cadets.

(a) Casual pay will NOT be processed for AC Cadets

USACC CIRCULAR 145-5, 12 October 2021



(b) Base pay starts on AC Regimental report date, even if the Cadet arrives the day prior. Cadets will be paid in accordance with DODFMR and Army Regulation 37-104-4 at a rate as published by DFAS. Cadet pay is subject to applicable state and federal taxes.

i. The majority of Cadets at AC should be in a current pay status for subsistence. MS IIIs are paid continuously from the start of the MS III year/contract date for 20 months less the training days for AC/Cadet Troop Leader Training (CTLT).

ii. The Leave & Earnings Statement (LES) remarks section will clearly describe the reduction of subsistence and the start of base pay for AC to include the dates for each type of pay. All Cadets should ensure funds have been deposited rather than assuming funds have been deposited into their applicable accounts. The majority of payments will be processed according to the mid-month or end-of-month pay dates.

(c) During AC, Cadet Pay questions should be addressed through the Regimental HRA to the CST Pay Team for resolution. Following AC, Cadet Pay questions should be addressed to the Detachment HRA or the Liaison at the CTLT, Nurse Summer Training Program (NSTP), and etc. location.

(d) Green to Gold (GTG) AD Option Cadets. GTG-AD pay and entitlements will be managed by Student Detachment at Fort Jackson.

f. Service Member's Group Life Insurance (SGLI): Eligible Cadets are covered by (SGLI) during CST. This form must be updated prior to CST; however, it is not required in the Cadet Personnel Records Folder.

(1) Coverage and Cost: Cadets are automatically issued the maximum SGLI coverage but may elect to decline or reduce coverage. Available options to choose from are no coverage up to \$400,000 coverage broken down in \$50,000 increments. The SGLI premium is currently \$ 0.07 per \$1,000 coverage per month (\$29.00 per month for maximum coverage). Cadets must pay the full monthly cost, whether for one day or the entire month. If selected for CTLT, Cadets must pay SGLI deductions for three months. SGLI covers BC, travel to and from FKKY and a period of 120 days following the completion of BC or conclusion of CTLT.

---

(2) Form completion: Cadets will complete the form on campus prior to the start of CST. Exercise care in its completion since it becomes effective should death or serious injury occur while enroute to or from, or while attending CST. Carefully consider before filling in the Next of Kin (NOK) and contact information as the person who will initially be notified in the event of serious injury or death at FKKY.

(3) SMP Cadets. Simultaneous Membership Program (SMP) Cadets already covered by SGLI with their SMP unit will not be charged additional premiums while attending CST.

g. MWR.

(1) Personal Affairs. Cadets should contact their CST Chain of Command if problems arise. Chaplains, Military and Family Life Counselors, and Personal Financial Counselors are also available for assistance.

(2) Laundry and Linen. Cadets and Cadre will be issued sheets, blankets, pillows, and pillow cases. These will be issued upon arrival and exchanges will occur IAW the training schedules.

(3) Laundry of cadre personnel staying in barracks is the responsibility of the individual Soldier. Soldiers will utilize washers and dryers provided in the barracks for personal laundry. Commercial laundry (coin operated) facilities are located off post for cadre as well.

h. Security of Personal Property. Trust, which develops between fellow Cadets, can easily lead to careless practices. The open bay barracks living conditions and easy access to the barracks make an inviting situation for a thief. The consequence of inadequate security rests entirely with the owner. To avoid loss, take the following actions:

(1) **DO NOT** leave money or valuables in the barracks.

(2) **DO NOT** bring expensive watches, cameras, or any stereo equipment. (Inexpensive watches and cameras suitable for field use are available at the PX, if required.).

(3) **DO** lock wall lockers and footlockers, even while you're showering.

(4) **DO** secure all approved prescription medications.

i. Early Release from CST. The Task Force (TF) Commander may grant early release requests as an exception to policy ONLY. Early releases may be requested by the Cadet upon arrival to CST, but there is no guarantee of approval.

j. Emergencies.

(1) The CST Chain of Command may authorize absences for emergency reasons. In the event of an emergency that may require a Cadet to be absent from CST, the Cadets family or NEXT OF KIN (NOK) must contact the American Red Cross (ARC) at 1-877-272-7337. This is important because a representative of the CST Commandant's Staff and TF Commanders can immediately authorize an emergency absence if the Red Cross has verified the emergency. The host university cadre may be available to assist as well. Government travel is not provided for Cadets who intend to return to training, following resolution of personal matters. The government is responsible for one round-trip ticket for Cadets for training.

k. Meals & Special Diets.

(1) Cadets (non-G2G-ADO) are authorized meal payment while attending CST IAW AR 30-1, The Army Food Service Program and AR 145-1, Senior ROTC Training Program: Organization, Administration and Training.

(2) The dining facilities (DFACs) can support special diets required for medical or religious reasons. Provisions for special diets do not apply to personal preference diets such as vegetarian. Ensure that dietary restrictions, including for religious accommodations, are annotated in CCIMM by the programs.

(3) All special dietary requirements must be annotated in the Cadet's CCIMM records prior to **12 MAR 2022**. This will allow the religious support agencies and/or DFACs adequate time to prepare for any special needs.

l. Post-CST Travel Vouchers.

(1) Program HRAs/NDEAs must submit Cadet travel vouchers. If Cadets cannot complete their travel voucher at CST they must complete their voucher NLT five (5) working days after travel is completed. (Traveler and program are responsible for retaining all associated receipts).

(2) Accuracy of orders and travel vouchers can impact Cadet Entitlements. It is extremely important to provide 1) complete travel information when preparing orders

---

and 2) receipts when filing claims. Direct questions to your respective brigade DTS Team or the Cadet Command G8 Accounting and Management Division DTS Section.

(3) GTG-AD Cadets who have dependents living with them are authorized a Family Separation Allowance if they successfully complete a minimum of 30 continuous days at CST. This must be processed by the ROTC battalion after the Cadet has completed CST.

---

## **Chapter 3 – Basic Camp (BC)**

### **3-1. Overview**

a. **Responsibility.** The program of instruction for BC accomplishes the same training (tasks) to the same standards required for the on-campus program during Military Science I and II Course (Basic Course).

b. **Training.** The BC Course incorporates a wide range of training events designed to develop/assess leadership potential and qualify designated applicants for contracting. BC is rigorous and demanding, both mentally and physically, and will test intelligence, ingenuity and stamina. BC training events provide a new perspective on an individual's ability to perform challenging tasks and to make sound decisions in demanding situations.

c. **Program of Instruction.** The structure of the training program is based on action-oriented training. Emphasis is hands-on, outdoor training with rapid and constructive feedback to Cadets. The training program is designed to inspire Cadets to become outstanding leaders with a sound understanding of traditional leadership values. It provides first exposure to the Basic Officer Leadership Course Common Core Task pre-commissioning requirements for lateral entry Cadets. Training is organized into five phases consisting of:

(1) **Instruction.** BC instruction is conducted by Army personnel qualified to conduct the training. Training includes Obstacle Course, Fieldcraft, Map Reading, Land Navigation, Marksmanship, Squad Tactics, Drill & Ceremony, Army Values, Ethics, Warrior Ethos, Leadership.

(2) BC is intentionally stressful and is designed to build individual confidence through the accomplishment of tough and demanding training. The days are long with frequent night training. Squad and platoon level training events develop collective cohesion (esprit de corps) and emphasize the necessity for teamwork.

(3) BC regiments begin training on specific dates as indicated in CST orders publications. Training is organized into separate iterations in a tiered structure, allowing each regiment to follow the same progressive sequence of training, ensuring standardized training and evaluation of all Cadets. Training events expose Cadets to military skills and leadership development; all of which are essential to enter into a Military Science Program.

(4) Assessment is continual and begins shortly after arrival at BC. The cadre advises, coaches, and ultimately records an official assessment of each Cadet's potential on a Developmental Counseling Form (DA Form 4856).

### 3-2. Cadet Information

a. Typical Training Day. Outlined is a typical training day for BC Cadets:

Time	Activity Description
0500-0530	Wake up, get dressed and make bed.
0530-0700	PRT
0700-0800	Personal hygiene, clean living area, breakfast.
0800-0900	Move to training by foot or bus.
0900-1230	Training.
1230-1330	Lunch (movement is integrated into this time as well).
1330-1700	Training.
1700-1730	Move to company area by foot or bus.
1730-1900	Dinner.
1900-2000	Reinforcement Time. Cadets reflect on day's events and receive leadership counseling.
2000-2100	Cadet Leader's time.

2100-2200	Personal Hygiene. Cadets generally use this time for barracks maintenance, uniform preparation and academic study for the next day's training.
2200	Lights out.

**Table 1 – Typical Training Day**

b. The Leader Development Program (LDP) is a critical part of BC. The LDP will provide assessments through a series of formal and informal assessments conducted throughout BC. The primary trainers are Regimental cadre to include Drill Sergeants, along with Observer, Controller, Trainer (OCTs) who provide feedback and assist in training Cadets. All Cadets will receive initial, midpoint, and end of course developmental counseling (DA Form 4856). They also have the opportunity to receive peer feedback. Cadre assess Cadet performance in leadership or team member roles and identify strong and weak areas of leadership competencies and attributes.

c. BC-Specific Training. Cadets must attend qualifying training events. If a Cadet fails to attend any of these events due to injury, illness, or other extenuating or mitigating circumstances, the cadre will make every effort to ensure the Cadet makes up the training with another regiment. If the Cadet cannot make up the training, the Regimental Training Officer (RTO) will review the Cadet's performance and recommends to the TF Commander whether or not the Cadet should be recycled or receive no credit for the course.

d. Qualifying Training Events. The primary focus of BC is training and development, not evaluation. However, there are several areas assessed based on established Army standards. The CST policy letter #10 will outline these events.

e. Arrival at BC.

(1) Cadets are assigned to a Regiment and Company upon arrival prior to in-processing. In-processing will include:

- (a) Reviewing physical exam/medical qualification, all medications brought to FKKY.
- (b) Receiving casual pay: \$50.00 (Optional)
- (c) Validating personnel records and travel.

(d) Accepting military clothing and equipment.

(e) Measuring HT/WT (and body fat measurement if necessary).

(f) Cadets reporting after 1800 on D-2 of the training cycle may not be eligible to receive completion credit with their Regiment, and may be recycled to a later Regiment.

### **3-3. Detachment Administrative and Logistical Preparation of Cadets**

#### **a. Qualifications and Documentation.**

##### **(1) Processing for BC.**

(a) Cadet Command Detachment representatives sponsor attendance to the BC; they conduct an interview, verify eligibility, and have necessary documents signed. Medical consent form (Figure 3-D) is required if less than 18 years old.

(b) A physical examination [BC Safe to Train physical or Department of Defense Medical Evaluation Review Board (DODMERB)] is required for attendance.

(2) Scholarships. Host universities address all issues regarding scholarships with the students associated with BC attendance and graduation.

b. Prior to the school reserving a training seat in the CCIMM Training module, the following must be accomplished:

##### **(1) Requirements for attendance.**

(a) Have no civil convictions unless a waiver has been granted. (Copies of all waivers should be hand-carried to in-processing)

(b) Must meet Army HT/WT standards (designated applicants must pass the initial procurement weight and body fat percentage standards: IAW AR 40-501, Table 2-1 and 2-2. \*\*An additional 3% is allowed beyond the initial procurement weight and body fat percentage with an approved waiver from the Cadet's respective Brigade Commander.

(c) Cadets must have started a physical by the program level. Professors of Military Science (PMS) must screen prospects early in order to reduce the number of no-shows and medical disqualifications. This process includes determining the



---

prospect's potential for success through the PMS's overall assessment and the physical exam. This process takes time--the PMS must actively recruit early in order to have the time required to successfully screen and select the best qualified and appropriate candidates for the authorized number of BC training allocations.

(d) Must be a U.S. or naturalized citizen between the ages of 17-32 . IAW AR 145-1 para 3-29 "An alien student may voluntarily enroll in the basic course or attend basic camp.

(e) Meets enrollment (full-time) and GPA (2.0 or greater) criteria.

(2) Waivers. A school is considered to have reserved a training allocation in the CCIMM training module when a Cadet is assigned to a training cycle. By reserving a training allocation in CCIMM, the PMS is authenticating the Cadet has met basic enrollment requirements and is ready to attend BC with all waivers resolved, except physical exam or medical. Cadets without an approved administrative waiver by the proper authority (e.g., civil conviction, RE Code, etc.) will not attend BC.

(3) IAW CC PAM 145-4 Para 2-54b, a Cadet may participate in camp training if approved by the waiver approval authority.

(4) The PMS will make an assessment of each candidate to determine if the student has the potential to succeed. This assessment is codified in the form of a waiver outlining clearly why the PMS believes the candidate should be afforded the opportunity to attend BC, and the student's potential to pass the Cadet Command Fitness Assessment (CCFA) standards given developmental time.

c. Seat Allocations. Published through CST Orders publications

(1) Historically, Brigade seat allocations for BC are published in CCIMM on or about the 1st of calendar year.

(2) Reservations for BC are based on allocations as directed by Cadet Command. Brigades will not exceed their allocations. Additional allocations should be requested through respective Brigade S2/3 sections.

(3) Gender allocations. If there are not enough female Cadets to fill designated allocations, male Cadets can be substituted as long as the total allocations do not exceed the Brigade's total allocation for a Regiment, or BC overall. If a Brigade exceeds its allocations in any given training cycle, then the overages of Cadets from the

Brigade are removed from the training allocation until the Brigade is within the limit of its allocation.

(4) Active Duty for Training orders for Cadets must be requested and generated utilizing Department of the Army Mobilization Processing System (DAMPS). HRA access to DAMPS and instructions for generating orders must be coordinated through respective Brigade S1. DAMPS orders requests and generation window will open on or around 20 March.

(a) Prior to Cadets reporting for training, all amendments for orders will be generated by ROTC Brigade S1. Once a Cadet reports for training, all required amendments will be generated by CST G1 staff. ROTC programs are not authorized to amend Cadet orders, after Cadets report for training.

### **3-4. Basic Camp Cadet Evaluation**

(a) In accordance with USACC Circular 145-5 and CST Policy Memorandum 10, BC Cadets are evaluated and counseled on a DA Form 4856 for the initial and mid-cycle counseling during BC. The final counseling and summary evaluation will be completed using the USACC Form 1059-BC Basic Camp Evaluation Report (BACER). Other evaluations are conducted as situations and circumstances warrant and recorded on Cadet Command Form 156-4. Cadet behavior is subject to evaluation at all times. Cadets may appeal their evaluations. Appeals will have a reasonable basis and are initiated directly with the evaluator at the time of counseling or through the Cadet's chain of command within 24 hours following counseling. The Cadet may request a review of the final counseling up to departure from CST. Platoon Tactical Officers (PTO) will collect evaluation data using the PTO Input File. This file will enable the aggregation and upload of evaluation data into CCIMM for production of the BACER.

(b). Cadets who fail to meet the approved standards will not receive completion credit for BC, unless they are given a waiver. Waivers are issued by the TF CDR at his discretion upon recommendation by the Cadet's Regimental cadre. Generally, in order for the TF CDR to consider a waiver, the Cadet's performance must have been above-average, and/or his/her potential for contracting must have been above-average, and exceptional circumstances exist which interfered with the CDT's completion of BC CST (e.g., a medical emergency, a family emergency, etc.).

(c). Counseling: BC Cadets will receive three written counseling sessions during CST. MS III squad leaders will conduct and document one initial and one intermediate counseling on DA Form 4856. The platoon Observer Controller Trainer (OCT) will provide oversight during each counseling session as part of the MS III

---

continued professional development. The platoon OCT will conduct and document the final counseling for each BC Cadet on USACC Form 1059-BC (BACER).

(1) MS III initial counseling for BC Cadets will include an explanation of graduation requirements, company standards and an initial review of Army values and expectations for performance. The initial counseling will occur NLT Day 3 of BC.

(2) MS III intermediate counseling for BC Cadets will include an assessment of the Cadet's performance to date and document strengths, areas of improvement, and overall performance. The intermediate counseling will occur NLT Day 17 of BC.

(3) OCTs will conduct the final counseling prior to graduation and will include a final assessment, strengths, areas of improvement, and overall performance and potential. The OCT counseling will serve as feedback for the Cadet as well as provide pertinent information to the PMS back on campus. The final counseling will occur NLT Day 29 of BC.

(4) All "Needs Improvement" comments will include mandatory remarks on the USACC Form 1059-BC and address deficient area(s), including recommendations for further development on campus. The counseling will accurately reflect the Cadet's strengths and areas needing improvement so the PMS can develop a plan for continued development during the Cadet's MS III year.

---

## **Chapter 4 – Advanced Camp (AC)**

### **4-1. Overview**

a. Purpose. AC is to train Cadets to Army standards, develop leadership, and improve leadership skills and attributes. Additionally, AC meets the Army BOLC-A Common Core pre-commissioning and summer training requirement as set forth IAW AR 145-1, AR 350-1, TRADOC REG 350-36 and CCR 145-03. AC is the most significant training and evaluation event in ROTC. Training is complex, challenging, and rigorous and is conducted in a stressful training environment.

(1) General. To meet the manning requirements, there will be eleven Cadet Regiments with associated training committees and staff positions. A regimental cycle incorporates a wide range of events designed to develop and evaluate leadership and officer potential. The events are mentally and physically demanding, and test intelligence, critical thinking, ingenuity, and stamina. These events provide a different perspective from the campus view on an individual's ability to perform exacting tasks and to make difficult decisions in demanding situations. AC observations, combined with campus observations and assessment, provides a more complete observation of a Cadet's leadership capabilities and limitations.

(2) AC training utilizes small unit tactical training as the vehicle for developing and evaluating Army Leadership potential. Training is organized into separate committees in a tiered structure. Each regiment follows a progressive sequence of training, ensuring standardized training and evaluation of all Cadets.

(3) The regimental training cycle builds on previous training events, beginning with individual skills and culminating with rigorous platoon-level training.

#### **b. Program of Instruction.**

(1) Training Program. The training regimen is sequential and progressive, starting with individual training tasks and building to complex collective training.

(2) Individual Training: To successfully complete AC, Cadets must perform in accordance to the criteria set forth in USACC CST Policy Memorandum 9.

(3) AC completion criteria. To successfully complete AC, Cadets must perform in accordance to the criteria set forth in USACC CST Policy Memorandum 9.

(4) Physical Conditioning. AC demands a high level of physical fitness. Cadets cannot keep pace with the training program if they are not in good physical condition upon arriving at AC. Remediation.

(2) There are times during Advanced Camp where Cadets are unable to complete Must Pass/Must Complete/Must Attempt Events due to illness or injury. The CST Commandant establishes, through Policy update each year, which Must Pass/Must Complete/Must Attempt can be completed On-Campus through Remediation after Camp for Advanced Camp credit.

(3) Remediation status is determined by Leader Development Review Board (LDRB) and the Cadet and assigned Brigade/Program is notified of the status through a CST Form 131.

(4) The Cadet's PMS is responsible for ensuring that the Cadet remediates the event to the CST standard and prepares memorandum through the brigade headquarters (requires brigade commander endorsement) to the Commanding General, USACC (Attention G37). A format is provided at Annex H. The memorandum needs to contain all relevant information on Cadet completion of the event to include dates, times, scores and location.

#### **4-2. Cadet Information**

a. What to Bring. Refer to the packing lists. If a Cadet is attending follow on training (e.g., Airborne, CTLT, NSTP), refer to the applicable Cadet Command CPDT MOI for additional uniform/ equipment requirements. Cadets must have a valid military ID card (not a dependent ID card) in their possession at AC.

##### **b. In-Processing Procedures**

(2) Cadet HT/WT will be conducted at the regimental area by the regimental cadre (body fat measurement if necessary).

(3) Cadets reporting after to CST 1800 on day two of the training cycle may not be eligible to receive completion credit with their regiment, and may be recycled to a later Regiment.

(4) Cadets will bring CAC, shot records, all medications, and all medical records not uploaded into Medical Sharepoint by ROTC program. All AC Cadets will undergo a medical screening and/or examination on Day 2/3 of CST for commissioning.

### **4-3. Detachment Administrative and Logistical Preparation of Cadets**

#### **a. Enrollment & Contracting Status for AC Attendance.**

(1) MSIII Cadets: Unless the Cadet has deferment approved by the appropriate brigade commander, all contracted Cadets who have completed their MSIII year must attend AC prior to enrollment in MSIV.

(2) All Cadets: All Cadets scheduled to attend AC, except immigrant aliens, must be under contract and (if applicable) enlisted in the US Army Reserves (USAR) or Army National Guard (ARNG), prior to reporting to AC.

(3) Other Cadets: Cadets other than those listed above who report to AC and are not properly contracted will be immediately released from AC.

#### **b. Scheduling & Regimental Cycle Assignments.**

(1) Historically, Brigade seat allocations for AC are published in CCIMM on or about the 1st of calendar year.

(2) Detachments will annotate the status and desired cycle assignment of all Cadets eligible to attend AC in the CCIMM training module. Ensure accuracy in AC status reports since they directly impact AC manpower and budgetary decisions.

(3) The CST Commandant will refine initial cycle assignments based on information provided and confirm cycle assignments as soon as possible. Specific instructions and suspense for input in the Training Module will be furnished at a later date.

(4) Specific cycle assignment requests will be considered only to accommodate specialized training or to meet Cadet summer school requirements in order to maintain mission set alignment.

(5) It is strongly recommended Cadets not be scheduled for Airborne or Air Assault School during the weeks prior to attending AC to prevent injuries.

(6) AC seat allocations: Will be published in CST orders publications

(7) Temporary Medical Conditions. Cadets who have pre-existing temporary medical disqualifying conditions will attend AC provided they obtain medical clearance

from the Cadet Command Surgeon. Cadets with current prescriptions for certain behavioral health medications may be immediately sent home and unable to train. Any Cadet suffering a significant illness or injury during the spring term prior to AC attendance must meet AR 600-9 standards, and hand carry treating provider full training clearance documentation.

(8) Deferment. Attendance and successful completion of AC is a pre-commissioning requirement. Cadets generally attend AC at the conclusion of their MSIII year. AC attendance may be deferred to the end of the MS IV year with the approval of the Brigade Commander. Medical problems, hardships, or compelling academic reasons for deferment are generally considered for approval. Additionally, Cadets considering Reserve Component service with a full-time, paid summer civilian internship may request deferment and will be generally considered favorably for approval. Nurse and Green-to-Gold Cadets are not eligible for civilian internship deferral. Cadet convenience, lack of adequate preparation, or PMS preference are not reasons to request deferment.

c. Active Duty for training orders for Cadets must be requested and generated utilizing Department of the Army Mobilization Processing System (DAMPS), prior to Cadets reporting to any training event. HRA access to DAMPS and instructions for generating orders must be coordinated through respective Brigade S1. DAMPS orders requests and generation window will open o/a 20 March.

d. GTG-AD must be put on TDY orders from Fort Jackson Student Detachment for all ROTC training events. USACC G1 will provide Student Detachment a roster of all GTG-AD in mid-March, on behalf of the GTG-AD, to have orders created for assigned training dates. GTG-AD will need to obtain a copy of those orders prior to departing for any training event.

e. Photo ID Cards & Identification Tags. Required Items and Guidelines.

(1) Valid Common Access Cards (CACs) and ID tags (to include required medical tags) are checked for accuracy prior to departure to AC. CAC must not expire before all summer training and return travel is complete.

(2) ID tags are authorized for issue by CTA-50-970.

f. Medical Record Requirements.

(1) Cadet Medical Record. Use appendix E – CST Medical Records Checklist IAW the guidance outlined below. Load records listed below to the medical records into CCIMMS. All records generated (e.g. consultations, lab results, etc.) must be uploaded to the medical records SharePoint and hand carried by the Cadet.

(a) Medical Waivers and Medical Determinations: Include copies of **ALL** approved medical waivers and medical determinations granted by the Cadet Command Surgeon for enrollment, contracting, or retention in the ROTC Program. Cadets who have known temporary disqualifications may attend AC provided they obtain medical clearance from the Cadet Command Surgeon.

(b) DD Form 2807-1. Report of Medical History (3 page form). Cadets will complete Items 1 through 29 on Pages 1 & 2. Only name and full social security number (SSN) should be completed on Page 3. Utilize the pre-filled form provided on the medical record sharepoint site.

i. Ensure all questions are answered. Care should be taken when completing this form, as an initial screening of this form is used to determine which Cadets need to be seen by a specialist during their AC Physical.

ii. Cadets must disclose all known medical conditions and any medications used since enrollment in the program. Concealment of a medical condition or medication can lead to adverse administrative actions up to and including disenrollment.

(c) One complete and DODMERB stamped copy of the Cadet's entrance medical examination (DD Form 2351, DD Form 2807-1, and DD Form 2808):

i. Include initial medical consultation and tests evaluated for entry into the ROTC Program.

ii. Include a copy of any subsequent medical examinations.

iii. Enclose a Memorandum for Record if the original medical examination is not available (i.e. lost, missing, destroyed, etc) signed by the BDE CDR.

(d) DD Form 2005, Privacy Act Statement – Health Care Records (dated Feb 76). Cadets must sign (print the name below the signature), whole SSN and date this form. This form allows the AC chain of command and key medical personnel to discuss the Cadet's medical status.



(e) Other Medical Documentation. Include all other medical documentation generated since the Cadet's initial physical. Examples include: medical determinations, diagnoses, procedures, results, activity limitations concerning any major injury, broken/fractured bones, serious illness or surgical procedures. Include any documents showing Cadets are cleared to return to duty from injuries listed on DD Form 2807-1.

(f) All PMSs or their designee are required to review all medical documentation for any pre-disqualifying medication prescriptions prior to loading the Cadet medical documentation. Record screening prevents Cadets with known disqualifying conditions/medications from being sent to AC unnecessarily and eliminates unnecessary cost to the government. See CST policy letters for prohibited medications. Any questions about medical eligibility to attend AC should be directed to the USACC Surgeon's Office prior to arrival at AC.

(g) Standard Safe to Train Physical Exam.

i. Prescription Medications. Cadets must declare all medications on DD Form 2807-1 box 8. Medications must be in the original container with the Cadet's name on the prescription. Physicians will review the medications, screen for potential drug interactions, and/or change prescriptions to something more appropriate to the training environment.

ii. HT/WT Screening. Cadets will be screened for height and weight using AR 600-9 standards.

iii. Pelvic Exams & Pap Smears. Pelvic exams and pap smears are not required during the commissioning physical process. The exams are required for flight physicals completed at AC.

iv. HIV Testing. IAW AR 600-110, the medical exam administered at AC will include screening for the HIV antibody for all AC Cadets.

v. Drug Testing. AC will conduct drug testing on all Cadets. Any Cadet testing positive for illegal drugs will be dismissed from AC and recommended for disenrollment IAW AR 600-85. Cadets who test positive for prescription medication will provide the USACC Drug Testing Coordinator the prescription and other relevant documentation for the medical review process and determination by the medical review officer. Hair follicle or other methods are not authorized.

---

vi. Immunizations. Cadets are immunized IAW AR 40-562. Cadets attending AC must have the following shots: Measles, Mumps, Rubella (MMR), Varicella (Chicken Pox) Hepatitis A, Hepatitis B and Meningococcal. Influenza vaccine is not required but encouraged. Cadets who do not have serologic evidence of immunity will receive immunizations (MMR, Varicella, Hepatitis A, Hepatitis B and Meningococcal) during AC. The COVID 19 vaccine is also MANDATORY to attend CST.

(h) CLASS 1A Flight Physicals. Flight physical will be performed on a limited basis at AC IAW current CST OPORD.

i. In addition to the examination and testing outlined above, TF MED assigned Flight Surgeons will administer Class 1A Flight Physicals during physical exam days of AC for Cadets to determine if they meet the general flight medical standards outlined in AR 40-501, Chap. 4.

ii. Cadets who desire to have a Class 1A Flight Physical at AC must enter Selection Instrument for Flight Training (SIFT) score in the CCIMM TRAINING Module by selecting the flight physical code "Y" and entering the numeric SIFT score in the appropriate field. Cadets who have not taken the Selection Instrument for Flight Test (SIFT), have scored below 40 on the SIFT, do not meet the OPORD AC Flight physical criteria, or do not meet the general medical standards will not be given a Class 1A Flight Physical at AC.

iii. Cadets receiving a flight physical are required to have dental pantographic radiographs taken prior to arrival at AC. Detachment cadre must verify the radiograph is on file. Cadets will not bring radiographs from their schools with them to AC. Those Cadets without pantographic radiographs will receive one during the flight physical.

iv. Female Cadets receiving a flight physical who have had a Pap screening within the past 13 months should bring the cytology results on the day of the exam.

v. The following are the most common medical conditions resulting in Class 1A disqualification IAW AR 40-501; however, it is not a complete list:

- a. Eye & vision standards (AR 40-501, Para 4-11 & 4-13).
- b. History of asthma or hay fever subsequent to age 13 (AR 40-501, Para 2-23d & 4-18).

c. Skull or vertebral fractures. Any history of head injuries and unconsciousness must be documented by medical records (AR 40-501, Para 4-23).

d. History of attempted suicide, history of behavior health treatment requiring treatment with psychiatric medications (AR 40-501, Para 4-23.j).

e. History of psoriasis (AR 40-501, Para 2-3 & 4-24).

f. Ulcers or ulcerative colitis (AR 40-501, Para 2-3 & 4-4).

g. History of drug or alcohol abuse (AR 40-501, Para 4-23.h & i.).

h. History of serious illness/disease such as polio, heart disorder, epilepsy, or other seizure disorders.

i. Acute or chronic sinusitis (AR 40-501, Para 4-20.e.).

e. Medical Disqualifications at AC. The CST Chain of Command will release from AC those Cadets found medically disqualified as a result of the AC medical examination or from injuries sustained at AC if a medical waiver is not granted. Cadets dismissed from AC for remedial conditions (except pregnancy) must have these conditions corrected and re-evaluated by the Cadet Command Surgeon.

f. Logistical Requirements.

(1) Use AC Clothing and Equipment Checklist, and the guidance provided below to fulfill Cadet logistical requirements for AC.

(a) Non-tariff Size Clothing. Detachments will submit requisitions for required non-tariff clothing by using DD Form 358 (Male) or DD Form 1111 (Female) and if applicable DD Form 150 (Special Measurement Blanks for Special Measurement Orthopedic Boots and Shoes) to their support installation by November of each year for school issued uniforms/boots for Cadets attending AC. For non-tariff ACUs/OCP to be issued at AC, send a copy of requisitions through your BDE S-4 to the G4.

(b) Non-tariff clothing includes extreme sizes (either small or large). The following ACU sizes are NOT stocked at the FKKY CIF. If you have a Cadet who wears these sizes you MUST submit through your BDE S-4 to the G4.

(i) XS-XXS

(ii) XS-XL

(iii) L-XXL

(iv) XXL-XL

(v) XXL-XXL

(vi) XXL-R

(vii) XXL-L

(2) Footwear. IAW CTA 50-900, Clothing and Individual Equipment, issue two pair of properly fitted combat boot (Tan) and six pair of wool socks. Issue boots as soon as possible in the Fall semester to ensure proper break-in before AC. Encourage Cadets to wear boots for extended periods of time. Blisters continue to be an issue for Cadets who do not adequately condition their feet prior to AC. Cadets will be issued an additional nine pair of socks from CIF upon in-processing at AC.

(3) Uniforms and Field Equipment. See CST Cadet Packing List, for items issued on campus prior to attendance at AC.

(a) Cadets attending follow on training (e.g., Airborne, CTLT) must bring uniforms IAW the Cadet Command CPDT MOI guidance for their specific training. These Memorandums of Instruction (MOIs) can be found on the Cadet Command Website.

(b) Cadets commissioning at the end of AC are required to bring their properly tailored ASU and beret. These must be inspected by cadre prior to the Cadet departing campus.

(4) CTA 50-900. See CST Cadet Packing List for items issued by CIF to Cadets during AC. These items will not be issued on campus prior to AC attendance. The provisions of AR 735-5, Policies and Procedures for Property Accountability, will govern for lost, damaged, or destroyed articles and their reimbursement.

(5) Personnel Records Requirements. Cadet must bring all records in accordance with Appendix D -Cadet personal records checklist.

---

## **Chapter 5 – Cadre Guidance**

### **5-1. General Administrative Information**

a. Brigades will maintain accurate contact rosters for their headquarters and for each school within their Brigade.

b. CST is a 24 hour, 7 days a week operations. As such, staff and LNOs must be able to make contact with someone at each brigade headquarters and at each school

c. Religious Accommodation.

(1) The Unit Ministry Team (UMT) works to perform and provide religious support for the Cadets and cadre during CST. The UMT consists of the CST Chaplain, Deputy Chaplain, and Chaplain Assistant. Each regiment also has a chaplain candidate who provides a ministry of presence as they learn the work of an Army chaplain.

(2) Religious services are scheduled throughout CST. Denomination specific services are provided as schedule and resources allow. Attempts are made to provide religious opportunities for Cadets who are not part of a Protestant, Catholic, Latter-Day Saints, or Jewish faith base. The UMT asks for advance notification from the Cadets' PMS if the Cadet does not follow any of these faiths so attempts can be made to provide support in advance of their arrival.

(3) Counseling is provided by the UMT to all Cadets and cadre. Chaplain candidates, as seminary students, are not endorsed army chaplains and cannot provide counseling services to the Cadets beyond basic encouragement, and therefore refer the Cadets to the CST Chaplain and Deputy Chaplain.

(4) Religious Services/Support. The Fort Knox and the CST Chaplain Staff will hold services for various faiths each week. Due to the training environment, they will often conduct services in the field and at other than routine times. Specify the denomination of choice to the Regimental cadre during the cycle assignment process.

d. Public Affairs. This headquarters plans information activities to enhance the Army image and visibility, create a favorable climate of public opinion, stimulate interest in the program, and provide information. We accomplish these objectives through Command Information, Public Information, and Community Relations Programs.

---

e. **Help Desk. A help desk, with an established toll free number is operational in the CST TOC 502-624-1500 beginning 1 May 2021 from 0830-1800.** The purpose is to answer Cadets' or their Family members' questions regarding BC or AC. It is important to remember, this help desk is not a message center. If Cadets or Family members have questions or need information regarding BC or AC, the personnel manning the desk is able to assist in providing or getting the answers to their questions. Cadre sending Cadets to BC or AC should provide a toll free number to the Cadet and their immediate Family members.

f. **Inappropriate/Unprofessional Relationships.**

(1) While at CST, Cadets will receive training on the components of sexual harassment, improper relationships, and fraternization between cadre and Cadets or between Cadets and other Cadets. Cadre and Cadets are expected to maintain the highest standards of honesty, impartiality, and professionalism to ensure the proper performance of our Cadet Summer Training mission. Inappropriate behavior will not be tolerated and it will be dealt with expeditiously and personally by the appropriate UCMJ or governing authority.

(2) All personnel will use the term Cadet as the term applies as to grade or rank. Conversely, non-contracted participants are students who are taking one of our ROTC electives (MSI or MSII). While we may refer to this population as Cadets during MS classes, their predominant public status is that of college "Students" at their respective universities. This clarification is issued for two reasons: (1) to avoid any misconception of a student's ROTC status and level of ROTC affiliation when responding to ongoing or potential public affairs incidents; and (2) so that USACC leadership is provided an immediate and clear understanding of a student's ROTC status when reviewing SIR and other communications regarding ROTC participants.

**Sexual Harassment.** Sexual harassment is a form of sex discrimination which involves unwelcome sexual advances, request for sexual favors, and other verbal or physical conduct of a sexual nature. Sexual harassment is prohibited by AR 600-20 and by the UCMJ. Sexual harassment is defined in AR 600-20 paragraph 7-7 and Conduct that involves unwelcome sexual advances, requests for sexual favors, and deliberate or repeated offensive comments or gestures of a sexual nature when:

(a) Submission to such conduct is made either explicitly or implicitly a term or condition of a person's job, pay, or career; or

(b) Submission to or rejection of such conduct by a person is used as a basis for career or employment decisions affecting that person; or

(c) Such conduct has the purpose or effect of unreasonably interfering with an individual's work performance or creates an intimidating, hostile, or offensive working environment; and

(d) Is so severe or pervasive that a reasonable person would perceive, and the victim does perceive, the environment as hostile or offensive. Improper Relationships. The regulatory restriction found in AR 600-20 prohibits relationships between members of different rank which gives the appearance of partiality, preferential treatment, or the improper use of rank or positions for personal gain, and are prejudicial to good order, discipline, and morale.

This regulatory guidance is further explained in applicable USACC and CST policy letters. This is especially true of the superior-subordinate relationship, which exists between cadre and Cadets as well as between Cadets in the same unit while at the CST. Personal and romantic relationships between senior and subordinate are perceived by all as a cause for partiality and preferential treatment, and are invariably the source of embarrassment to this command. Therefore, personal and romantic relationships between senior and subordinate are strictly prohibited. Cadets and cadre must conduct themselves in a professional manner and in a manner which cannot be misinterpreted as an improper relationship.

(a) Prohibited relationships.

(1) Cadre and Cadets. Any relationship between cadre and Cadets, not required by the training mission is prohibited IAW AR 600-20, paragraph 4-14/15. This definition includes and is not limited to dating Cadets, writing personal letters, text messages, e-mails, exchanging personal communications on social media, having personal telephone conversations unrelated to the training mission, playing cards, gambling, dancing, entertaining in personal residences, sharing accommodations in a hotel/motel, transporting in a POV, or any other conduct of a personal or sexual nature.

(2) **Cadre personnel are prohibited from "Friending" or requesting to be a "Friend" of Cadets through use of personal social media outlets/networking sites (Facebook, Snapchat, Twitter, etc.).** However, social media outlets/networking sites, such as official unit sponsored pages directed at conveying official Army

---

information, communications, or activities may be used for official/professional communication between cadre and Cadets in training.

(3) Cadets. Any relationship between Cadets in training not required by the training mission is prohibited IAW AR 600-20, paragraph 4-14/15. This definition includes and is not limited to dating, sharing accommodations, or any other conduct of a personal or sexual nature while participating in the CST training cycle.

g. Physical contact with Cadets for any reason other than to make necessary training-related corrections. Exceptions to this are where the safety of the Cadet is in question (for example, heat exhaustion, physical injury, etc.). Cadre members are not required to ask the Cadet's permission when making necessary corrections; however, effective trainers tell Cadets what they are going to do prior to doing it.

h. Failing to give Cadets reasonable time to eat meals is prohibited. Depriving Cadets of meals or restricting meal choice is likewise prohibited as a form of discipline. Drill Sergeants and cadre will refrain from disrupting the serving line, except for immediate safety considerations. Cadets shall be allowed at least 10 minutes to eat; this is time spent seated and does not include time spent in the serving line. Leaders will protect this time for the sole purpose of refueling to optimize performance.

i. Contact by cadre members with Family members of Cadets in any manner outside the performance of official duties is prohibited.

j. Requiring or encouraging Cadets to purchase common use items or common area cleaning supplies with their own funds (for example, bay cleaning supplies, toilet paper for common latrines, etc.) is prohibited.

k. Fundraising.

(1) No cadre member may sell any product, service, or opportunity to Cadets.

(2) No Cadets will be directed to participate in or make purchases at any authorized fundraising activities conducted in the Brigade, Battalion, Company, or training area.

(3) Family Readiness Group (FRG) fundraising activities are only permitted IAW AR 608-1 Appendix J, Army FRG Operations, AR 210-22, and Private Organizations on Department of the Army Installations.

USACC CIRCULAR 145-5, 12 October 2021



(4) Cadets may voluntarily contribute to officially authorized campaigns (such as, Combined Federal Campaign, Army Emergency Relief, etc.) or make chapel offerings.

(a) Individuals who have been subjected to sexual harassment or improper advances should be advised to report it to their Chain of Command, SARC, VA, or SHARP Hotline. **The USACC HQ and Brigade Sexual Assault Hotline, 24/7 assistance, can be reached at (855) 472-6538.**

I. Treatment of Cadets. Treat all Cadets IAW Schofield's definition of discipline: "The discipline which makes the Soldiers of a free country reliable in battle is not to be gained by harsh or tyrannical treatment. On the contrary, such treatment is far more likely to destroy than to make an army. It is possible to impart instruction and to give commands in such a manner and such a tone of voice to inspire in the soldier no feeling but an intense desire to obey, while the opposite manner and tone of voice cannot fail to excite strong resentment and a desire to disobey. The one mode or the other of dealing with subordinates springs from a corresponding spirit in the breast of the commander. He who feels the respect which is due to others cannot fail to inspire in them regard for himself, while he who feels, and hence manifests, disrespect toward others, especially his inferiors, cannot fail to inspire hatred against himself." MG John M. Schofield, 11 August 1879.

(1) Treat Cadets with the same respect, fairness, and regard for dignity accorded to all Cadets, regardless of race, gender, creed, etc.

(2) Provide sufficient time for Cadets to conduct personal hygiene, take prescribed medications, perform rehabilitative exercises, and apply ice therapy, when directed by medical authorities or appropriate self-care instructions.

(3) Afford Cadets the opportunity to participate in scheduled religious services, but do not direct or coerce participation in any service. Afford those Cadets who choose not to participate in religious services the opportunity for secular personal time. Personal time activities will not include barracks maintenance or similar activities offer Cadets no meaningful choice. The intent is to make it clear religious activities are voluntary, not command directed.

m. Corrective Training and Corrective Action.

(1) General. Corrective training and corrective action are tools available to leaders to rectify minor deficiencies, simple infractions, and less serious breaches of discipline, to focus the attention of Cadets, and to inspire compliance with Army standards. At no time is corrective action meant to demean, belittle, or embarrass a Cadet. The effective leader knows when to use permissible corrective training and NOT excessive or unauthorized physical activity to coach, teach, train, and mentor Cadets who are not meeting the standard. The following definitions apply:

(a) Corrective Training. Corrective training is for Cadets who have demonstrated they need, and would benefit from, additional instruction or practice in a particular skill. Corrective training should be directly related to the military skill the Cadet is deficient in and assist him/her in meeting the standard. AR 27-10 and AR 600-20 should be referenced.

(b) Corrective Action. Non-punitive actions used as a motivational tool by authorized cadre to immediately address deficiencies in performance or conduct and to reinforce required standards. By virtue of administering corrective action, there is recognition the misconduct did not result from intentional or gross failure to comply with standards of military conduct. Corrective action is inappropriate for situations requiring additional training to master a specific level of skill proficiency, or in matters where punishment is administered as a result of federal law or action. AR 27-10 and AR 600-20 should be referenced.

(c) Other Corrective Action. Nonphysical tasks may be used as corrective action instead of physical exercise. Requiring a Cadet or group of Cadets to recite the Cadets' Creed is an example of other action-based corrective action.

(2) Leaders must exercise good judgment in the administration of corrective action. Corrective action may be applied to entire units if appropriate (correcting an entire platoon failing to show teamwork during Soldier First Phase in a given training event by having them do five repetitions of the pushup, for example), but will be focused at the individual level whenever possible. Improper use can lead to unauthorized mass punishment or hazing. Cadets who are occupying leadership positions are prohibited from administering physical exercise as corrective action. Prior service Cadets in training are similarly prohibited from administering physical training as corrective action.

(3) Punishment. The imposition of specific requirements, actions, or restrictions are designed to reinforce good order and discipline and must be approved by the CST

---

Commandant and be IAW applicable laws and regulations. Recommend the Commandant consult with SJA prior to imposing punishment.

n. Cadet Abuse and Prohibited Practices.

(1) Cadet abuse is any improper or unlawful physical, verbal, or sexual act a cadre member commits against a Cadet. Examples include extreme exercise-based corrective action not IAW PRT, extreme profanity, sexual misconduct, extortion, inappropriate fundraising, or prohibited relationships. Only a commander can determine an incident as Cadet abuse.

(2) Hazing.

(a) Hazing is explicitly forbidden in AR 600-20 para. 4-19 and is similarly punishable under the UCMJ. It is a form of harassment that includes conduct through which Soldiers or DA Civilian employees, without a proper military authority or other governmental purpose but with a nexus to military service, physically or psychologically injures or creates a risk of physical or psychological injury to Soldiers for the purpose of initiation into, admission into, affiliation with, change in status or position within, or a condition for continued membership in any military or DA Civilian organization. It can be conducted through the use of electronic devices or communications, and by other means including social media, as well as in person.

(b) This definition includes and is not limited to playing abusive tricks, threatening or offering violence or bodily harm to another, striking, branding, tattooing, any forced or coerced consumption of alcohol, drug, or tobacco product, or causing the harmful, excessive, or abusive consumption of liquid, food, or any other substance.

(c) Hazing does not include command authorized mission or operational activities, the requisite training to prepare for such missions or operations, administrative corrective measures, extra military instruction, command authorized PT, and other similar activities the commander authorizes.

(d) Cadets not exercising proper hygiene are counseled and referred to the Company Training Officer for further evaluation. In no circumstances are Cadets forced to shower.

(e) Sexual harassment, fraternization, or inappropriate or unprofessional relationships is explicitly forbidden IAW AR 600-20 and may violate local regulations. These offenses may be punishable under the UCMJ.

o. Cadet Abuse Investigation and Reporting.

(1) Report all incidents of alleged Cadet Abuse IAW CST CCIR and SIR reporting procedures, to the CST Chain of Command. Regiment Training Officer (RTOs) are responsible for reporting Cadet abuse allegations as defined in these guidelines unless the RTO can determine within (two) 2 hours the allegation is non-credible. TRADOC Emergency Operations Center will forward TRADOC OPREPs concerning Cadet abuse to the TRADOC DCG-IMT and the TRADOC Staff Judge Advocate (SJA). TRADOC OPREPs provide the initial data for the TRADOC Cadet Abuse Coordinator.

(2) RTOs will promptly conduct a preliminary inquiry IAW Manual for Courts Martial Part II, Chapter III, Rule 303, into every Cadet abuse allegation, regardless of the nature, magnitude, or source of the complaint. For some allegations, a quick and informal interview of the complainant and any witnesses is all which is required. Other allegations may require more extensive command or law enforcement investigation. RTOs will consult with their legal advisor when conducting an inquiry or evaluating evidence concerning all allegations of Cadet abuse.

(3) RTOs will document and maintain records of all preliminary inquiries into Cadet abuse cases, including those the RTO determines are non-credible. Regimental Training Officers through local SJA will provide supplemental information by filling out TRADOC Form 350-6-1 (Training Abuse Report) on all Cadet abuse OPREPs and submit to TRADOC SJA in an accurate and timely manner (not to exceed 4 working days from notice of the event). Until final disposition of each case, commands through local SJAs will submit a status update through local SJAs, no later than the 28th of each month. Updates will be transmitted electronically to the TRADOC TAR and must include cases represented by case number and current status. This process will continue for every open case until the case is closed. A final TRADOC Form 350-6-1 will be completed and forwarded to the TRADOC TAR to report final disposition.

(4) Suspension Actions.

(a) Preliminary Inquiries. RTOs should not automatically suspend DSs, PSGs, or other cadre simply because they are pending a preliminary inquiry into a Cadet abuse allegation. RTOs will make suspension decisions based upon the facts of

---

each case, and may suspend individuals pending a preliminary inquiry if it will aid the inquiry, benefit the training environment, or for other valid command reasons.

(b) Investigations. Suspension of a DS or PSG from assigned duties is required when a serious incident occurs requiring an investigation IAW AR 614-200, paragraph 8-17d. For all other incidents, the CST Chain of Command has the discretion whether or not to temporarily suspend the cadre member from his or her duties. A serious incident consists of any actual or alleged incident, accident, misconduct, or act, primarily criminal in nature, and because of its nature, gravity, potential for adverse publicity, or potential consequences warrants timely notice to Headquarters, Department of the Army (HQDA). Investigations include, but are not limited to, investigations conducted IAW AR 15-6 or those conducted by the Criminal Investigation Division (CID) or a military police investigator.

(c) Considerations. In addition to the severity of the underlying incident, RTOs should make any suspension determination only after considering all evidence available. The number of witnesses, or volume of physical evidence, does not determine the weight given to the evidence. Commanders should evaluate the evidence for factors including, but not limited to the witness's demeanor, opportunity for knowledge, information possessed, ability to recall and relate events, and other indications of truthfulness.

(d) Suspension of Special Duty Assignment Pay (SDAP). Suspension of DS SDAP will be done IAW AR 614-200, paragraph 3-22e (8). DS SDAP will not be suspended based upon the initiation of any inquiry or investigation into alleged DS misconduct.

## **5-2. Common to Cadre— General Information**

### **a. Conduct and Behavior.**

(1) Army Policy permits smoking in designated areas only. CST Policy is no smoking or use of any tobacco products in the presence of Cadets or on committee sites during training. There is also no smoking in any Government buildings or vehicles.

(2) All Cadet Command cadre in support of CST will be subject to the award authority of the CST Chain of Command and the UCMJ authority of their respective parent Brigades. UCMJ authority for FORSCOM and USAR personnel will reside with parent units as clarified by applicable memorandums of agreement/understanding

(MOA/MOU). Brigade-level UCMJ authority for all military personnel will reside with habitual Brigade Commanders.

(3) Cadre behavior is expected to be above reproach at all times. Read, understand and comply with all Fort Knox and CST policies.

(1) Cadre are restricted from Cadet areas and will not have ANY interaction with Cadets if they have consumed any amount of alcohol.

(2) While wearing military attire, cadre may not enter off-post establishments where the basic means of revenue is the sale of alcoholic beverages. You may not consume alcoholic beverages in an off-post establishment while in ACUs/OCPs. Kentucky's DUI blood alcohol level is .08% and is **STRICTLY** enforced.

(3) All Cadre are subject to random drug testing during CST. Cadre and Cadets who test positive for prescription medication will provide the USACC Drug Testing Coordinator the prescription and other relevant documentation for the medical review process and determination by the Medical Review Officer. Cadre or Cadets whose urine has tested positive for illicit drugs may obtain a retest at any DOD FTDTL, at no cost to the individual when a sufficient quantity of the specimen is available for retesting. Hair follicle or other methods are not authorized.

(4) Designated cadre may also be issued government cell phones for official use. Personnel assume full financial liability for all calls made. These call logs are monitored. Unlike many commercial calling plans cadre might have on their personal phones, CST is billed for ALL minutes used (incoming & outgoing, local calls, on-post, and calls to toll-free numbers).

(5) All leave and pass requests for timeframes that fall within the CST tour of duty for cadre must be approved by CST Chain of Command.

(6) If cadre require an updated official DA photo while TDY at FKKY, the Fort Knox photo lab is open by appointment only. Appointments can be scheduled at <http://www.vios.army.mil/>.

(7) Cadre who wish to review their flight records or have questions regarding flight records, should contact the CST MEDOPS section. Flight physicals require two months advance coordination for appointments.

(8) The CST mail room provides mail services for each CST Regiment, Staff or training section. Stamps are available in the Disney Complex Troop Store, all AAFES facilities on Fort Knox and in the Fort Knox main PX. Complete postal services are available at the Fort Knox Main Post Office. All out-going mail from the CST mailroom must be Official Mail ONLY. Official envelopes cannot be used for personal mail. Your CST mailing address is:

**RANK, LAST NAME, FIRST NAME  
HQ, USACC, BC/AC/STAFF SECTION/COMMITTEE (indicate which)  
XX REGT, XX COMPANY, XX PLATOON (or training section)  
24 RHINELAND STREET  
FORT KNOX, KY 40121-5117**

(9) Fort Knox has an on-post theater, bowling lanes, service clubs, library, auto craft shops, tennis courts, gymnasiums, swimming facilities, outdoor equipment rental facility, and an 18-hole golf course. You must comply with all regulations concerning licenses and safety. Boat rentals require boat safety certification. Priority at CST is training. MWR should be utilized only after all requirements are complete.

b. General Information

(1) Medical and Dental Care. Active Duty and Reserve Soldiers needing medical care will use the Nelson TMC BLDG 5949 for routine sick call. Dental sick call will be provided M-F at Jordan Dental and is located on 1st Infantry Division Road, or call 502-626-8301.

(2) Cadre may report directly to Jordan Dental Clinic during sick call hours. USACC cadre requiring an annual dental exam and cleaning during CST may call 502-626-8303. Cadre must have ID card to be seen. It is recommended that cadre bring their military dental record if in their possession but civilian dental records are not needed. Cadre must take their dental records with them prior to departing CST.

(3) All Cadet dental sick call patients need to report to the Nelson Troop Medical Clinic (NTMC) prior to being seen at the Jordan Dental Clinic. TF-MED will transport Cadets to the dental clinic and back to NTMC prior to returning to their Regiment/Committee. Cadets must have their ID card and a signed DD Form 689, Individual Sick Slip and be in an Army uniform.

(4) Dental emergencies after duty hours (1530hrs) should report to the Acute Care Clinic (ACC) at Ireland Army Health Clinic during Acute Care Clinic operational hours (0800-2000 M-F and 0800-1800 Sat and Sun with closure on holidays). Outside of ACC operational hours, serious dental emergencies should report to the nearest local Emergency Room. DENTAC provides CST MEDOPS with an After Hours/On Call Provider roster for evenings and weekends which coincide with the Ireland Acute Care Clinic hours.

(5) DA Civilian Timekeeping and Compensation for Duties.

(a) In accordance with USACC Employee Handbook, all GS employees at CST are on a maxi-flex schedule and may be required to work any 80 hours in each pay period.

(b) All overtime or compensatory time allowed during CST will be strictly managed and must be approved by the CST Chief of Staff or designated representative prior to hours being worked. There are **NO EXCEPTIONS** to this rule.

(c) All DAC timekeeping and administrative management will be handled by the CST G1, in accordance with CST AD-SOP.

(d) Employees may be authorized to work on ROTC program business, during the CST duty day, if mission permits. Employees may be authorized to work overtime hours on program business, if required. All duty hours are required to be supervised.

(e) All DACs in a Testing Designated Position (TDP) are subject to random drug testing IAW AR 600-85, DA PAM 600-85. Once notified by the USACC Drug Testing Coordinator, supervisors will inform employee of date, time and location for the drug test.

(6) 2LT information

(a) Ensure 2LT that were in a Reserve or National Guard unit while a Cadet complete all paperwork to include unit personnel updating their entry in TAPDBR (USAR database) or SIDPERS (ARNG database) to release them from the unit so they may obtain an Active Duty ID card and all the benefits they are entitled to for themselves and their family. NOTE: If not properly released from the Reserve or Guard



unit, they will experience delays in obtaining an Active Duty ID card and associated benefits

(b) 2LT Personnel records must be hand-carried to CST, in accordance with the Lieutenant In-processing Checklist, APP F.

(c) 2LT should not expect to receive their first paycheck until 4-6 weeks after reporting to CST. Leave and Earning Statements may not be accessed from the "My Pay" system until 6-8 weeks after in-processing CST. All 2LTs should be prepared to have adequate money (~\$200.00) on hand to cover expenses until first paycheck.

(d) 2LT are not currently eligible to receive a Government Travel Card. As an exception to policy, they may have to request an Advanced Travel Payment (ATP) option. The request must be submitted to DFAS – Rome, NY by the school no more than 10 days prior to their Active Duty date. Advance Travel Request may be faxed, emailed or mailed to the appropriate address below. The request will be accompanied by a direct deposit authorization and a voided check. Cadet Command Orders published for 2LT should read that "Traveler is not a government credit cardholder and that Advance is authorized." All requests should be accompanied with the Travel Advance Request.

Address: DFAS-Rome  
Attn: Travel  
325 Brooks Road  
Rome, NY 13441

FAX: 317-275-0330

Email: DRO-TRAVELPAY-CCC@DFAS.MIL

(e) All 2LT may request an Advance Pay during CST in-processing. Advance pay is deducted from regular pay in monthly increments. It may take up to 14 working days to receive money under this option, assuming the in- processing packet is correct/complete. This pay will be directly deposited to the bank account indicated on SF 1199A.

(f) Direct Deposit Sign-Up Form) must be completed with a legible bank account number. Once the 2LT have submitted a Direct Deposit Sign-Up Form, inform them to NOT CLOSE THAT ACCOUNT. This account is where their pay will be electronically sent.

(g) Ensure 2LT orders reflect their desired mode of travel. If the orders are not correct, contact HQ, Cadet Command G1, Accessions Division, to have the orders changed prior to the date indicated on their orders. DO NOT wait until after the fact to

request changes to orders. Travel that does not comply with the mode designated within the 2LT orders may result in changes to Active Duty start date, loss of pay and entitlements, or loss of leave.

(h) 2LT are authorized and strongly encouraged to drive POV with travel time IAW orders. 2LT will not begin travel prior to their Active Duty accession date. Reimbursement for mileage and per diem will be processed by USACC G8 at the rates in effect at the time of travel. 2LT need to be briefed in detail by their School cadre on the ramifications of the various modes of travel to and from Fort Knox. They should also be made aware that Fort Knox and its surrounding areas do not have a public transportation service and a privately owned vehicle may be necessary for off duty transportation.

(i) If 2LT orders authorize them a Do It Yourself (DITY) Move and they plan to do a DITY move, they should check with the nearest transportation office to ensure the preparation is done correctly prior to departing for CST. The CST training schedules may not allow time for transportation briefings. Additional information about household goods entitlements can be found at: <https://move.mil/>

(j) 2LT must report to CST G1 up to 7 days prior to CST departure and receive copies of amended orders, complete travel voucher documents, DA Form 31, and receive out-processing guidance.

(k) 2LT are not authorized to return to their campuses following CST to perform duties in a Permissive TDY status as "Home Town Recruiters."

(l) While serving at Fort Knox as CST cadre, all leave for 2LT must be approved by Commandant or designated representative. 2LT leave may not be approved at TF level or by ROTC program PMS.

(m) 2LT that experience a legal name change prior to reporting to CST will be processed while at CST under the legal name reflected on their commissioning documents. All requests for military name change must be submitted and processed at first duty station.

c. CST TDA & Personnel Issues/Preparation

(1) All Detachments can expect to be tasked to provide personnel to perform duties at BC/AC as either instructors, staff, or in an administrative or logistical role. In

---

order to better prepare cadre for performing duties as OCTs. The requirements are listed below and additional information will be posted on the Cadet Command Black Board site. Each BDE will ensure all AR350-1 annual training is complete and track training completion as defined in the CST order process. The critical tasks include but are not limited to:

- (a) SHARP On-line Training
- (b) SHARP Class
- (c) EO Training (Fraternization & Hazing)
- (d) EEO Training (Individual & Supervisor)
- (e) CST SOP Review
- (f) Cadet Command Circular 145-05 Review
- (g) CST Policy Letters
- (h) Lightning Safety
- (i) Information Assurance Documents (Cyber Awareness Challenge, AUP, Form 101).

(2) All Cadet Command personnel need to be prepared to drive a government vehicle while at CST; therefore, all are required to have in their possession a valid state driver's license and will have completed the items listed below:

- (a) Vehicle Licensing (GSA / 15 Pax Van).
- (b) Valid State Driver's License.
- (c) DA348 and OF346 (for type vehicle). The OF 346 must be signed the Brigade CDR or their designated representative.
- (d) 15-Passenger Van Driver Improvement Course on Blackboard.
- (e) Complete hands-on training for the safe operation of a 15-passenger van (annotated on the DA 348 and OF 346, signed by the BDE).

(f) 15-passenger van drivers will read and comply with the Cadet Command 15- Passenger Van Safe Operation Policy.

(g) Drivers licensed on trailers being used (annotated on the DA 348 and OF346 signed by the BDE).

(h) All Terrain Vehicle (ATV) Training.

(3) Brigade Requirements. Brigades will be tasked by the Cadet Command Commander to fill specified (or in some cases, directed by-name) slots for CST. It is expected, following the initial fill by Brigades that unforeseen changes will occur. To rapidly respond to changes, the following information applies:

(a) Brigades must pay close attention to any trailer data on the TDA outlining specific grade, branch or experience level when assigning personnel to specific positions.

(b) Brigades must be aware of any physical limitations on personnel they are assigning. Do not slot someone who has a profile against walking or wearing field gear into regimental or tactical positions. Common sense should be a guideline.

(c) Historically, shortfalls occur with very short notice, often after CST has begun. Should an individual fall off the TDA for whatever reason, the CST TDA Manager or Cadet Command LNO will first make contact with the respective Brigade TDA manager to backfill the vacant position with a qualified individual unless relieved of the tasking by the Cadet Command G3, who will then reallocate the tasking within the command.

(d) The Brigade TDA manager will confirm whether or not the Detachment experiencing the shortfall can fill or if another Detachment within their Brigade will fill. If the Brigade cannot fill, then the replacement must be arbitrated through Cadet Command.

(e) The Cadet Command manning document manager may direct AC to contact a Brigade directly. Brigades must maintain an On-Call Roster of personnel for immediate response. Lessons learned indicate the following guidelines will assist:

(1) As taskings will be by specific type and grade, Brigades will maintain five (5) separate on-call categories: Officers, NCOs, contracted cadre, HRAs, and LOG techs.

(2) Additionally, Brigades will inform the individuals of where they stand on this list ahead of time (i.e. CPT Smith, you're next up for any backfills, or HRA Jones you're fifth in line of HRAs so low probability). By letting the individuals on the "on-call" roster know their probability of call up, replacing a shortfall becomes much easier.

(f) Brigades must maintain contact rosters for the headquarters and for each school within their brigade to fix TDA problems and to contact for Cadet issues. AC and BC are seven (7) days a week operations, requiring Brigades and schools to be available for contact.

(g) All Brigade S6 must assign Regimental cadre from their respective Brigade in CCIMM training module. Cadre must be aligned with their CST Regimental officer assignment under the CST Administration tab no later than 10 days prior to cadre report date.

(h) All USACC cadre must have an active RSN account prior to reporting to CST. Personnel that have not logged into CCIMM within thirty days must contact their Brigade S6 to have account re-activated. Failure to have an active account prior to reporting to CST will cause delay in access to network on Fort Knox.

d. Vehicle Requirements.

(1) Selected Cadet Command Brigades will be directed to bring Non-Tactical Vehicles (NTVs) to FKKY for use at CST.

(a) GSA Vehicles due replacement during the GSA Fiscal Year (FY) Vehicle buy (Apr-Jun) will not be tasked.

(b) The use of Army owned or controlled NTVs is restricted to official purposes in accordance with AR 58-1.

(c) Brigade vehicles are tasked to fill specific needs. No substitution of vehicles is allowed. Do not remove seats (reducing seating capacity) from tasked vehicles, or substitute mini-vans in place of 15 passenger vans (or vice versa).

(d) Brigade vehicles will be delivered to CST in the following condition:

- Clean interior and exterior
- Current Vehicle Maintenance completed

- Vehicle configured for full capacity seating
- Complete Operational Vehicle Maintenance (OVM) kit (spare tire, jack, lug wrench, etc.)
- Valid GSA credit card for the vehicle.

(e) Brigade vehicles tasked to support CST will report to the ROTC Motor Pool for in-processing during the hours of 0800-1100 on the required delivery date. A walk around inspection will be conducted and photos taken of the exterior vehicle condition.

(f) Brigade vehicles at CST are subject to the same logistic controls as all other NTVs.

(g) When possible, detachment vehicles will be assigned to support an element with a cadre member from the same brigade.

(h) Early release of school cadre does not justify early release of the school's vehicle.

(i) While air is the preferred mode of travel, Civilians may be authorized to drive a POV to CST, with mileage reimbursement according to JTR, Chapter 2, Para 020210 (eg. Reimbursement not to exceed x1 travel day implies reimbursement for rest stop not authorized). In and around mileage reimbursement of up to 15 miles per day is authorized and a mileage log must be kept showing days, places, and number of miles. For travel over 400 miles one-way or 800 miles roundtrip a Constructive Travel Worksheet (CTW) must be completed and uploaded in the DTS Authorization as a substantiating record. When completing the CTW the traveler will complete CTW Sections 1-3 (all required and applicable transportation costs associated with air travel). Government-provided transportation while at FKKY is limited and prioritized according to mission requirements. Personnel that require government-provided transportation while at FKKY should expect to utilize shuttle services and shared transportation assets. Travel Compensatory Time (Travel Comp) must be pre-approved, in accordance with USACC Employee Handbook, and a copy of approval must be provided upon in-processing.

(j) Soldiers are not authorized reimbursement for in and around mileage for POV use during CST.

(2) Government Vehicles.

(a) Cadre must possess DA Form 348 (Equipment Operator's Qualification Record) and OF 346 (U.S. Government Motor Vehicle Operator's Identification Card) at CST. Contact the CST Fleet Manager for any questions or coordination.

(b) If possible, CST-bound cadre should be licensed at their local support installation before CST and will have information verified and annotated.

(c) Damage to the vehicle. All accidents and incidents will be reported to the driver's direct supervisor within 2 hours of the incident. The supervisor will report the incident to their immediate supervisor, CST TOC, CST S4, and CST Safety. Based on the circumstances of how the vehicle was damaged, an investigating officer will be appointed to determine liability in all vehicle accidents. In the event an individual is found negligent, he or she can be held financially liable. The Estimated Cost of Damage (\$5000 or more) will determine if an Army Ground Accident Report (AGAR) is required; once completed, forward it to CST Safety for processing.

(d) Each day, prior to first use of the government vehicle (highly encouraged each time the vehicle operator uses the government vehicle), the operator will conduct a PMCS of the vehicle and will conduct a complete walk-around inspection of that vehicle in order to identify any new damage to the vehicle and to ensure there are no obstacles or obstructions near or around the vehicle that could cause potential damage or impair drivability. Once complete, the operator of that vehicle must fill out the Motor Vehicle Usage Log to ensure that the date and time of departure are recorded. Throughout the day, each time a new operator assumes responsibility for a vehicle, he/she will conduct the same walk-around inspection and will identify all deficiencies, note any discoverable damage prior to assuming responsibility, and will fill out all required forms properly. While in operation, all operators should use a ground guide when available while backing up GSA vehicles (vans, trucks, box trucks, trailers, light sets, generators, or any other vehicle). **This is mandatory for 15 passenger vans, box trucks, and buses with no exceptions.** Operators who tow trailers, light sets, water buffalos or generators will ensure the trailer is secured to the towing pintle or towing coupler with a cotter pin. Once secured, it is the operator's responsibility to ensure the cargo they are hauling is properly secured. At no time will any operator drive an overloaded vehicle. All 15-PAX vans and box trucks will have a driver and an assistant driver when transporting passengers or cargo. All 15-PAX vans and box trucks must be ground guided to and

---

from the gas pump to ensure pylons are not hit during the refueling process. Only 87 octane fuel is allowed per G4 guidance for non-diesel vehicles.

(e) Proper attire and footwear must be worn at all-time during usage of GSA vehicles. Open toed footwear (e.g. flip flops, crocs, sandals, or any footwear that exposes any side of the feet or toes) are a safety hazard and do not comply with the standards. This consideration applies to the operation of the vehicle and the motorpool area, on or off duty. IAW AR 385-10 dated 24 Feb 2017.

(f) All vehicles owned, leased, or rented utilizing funds are classified as government vehicles (i.e., GSA, leased, rented, and tactical vehicles). No such vehicle shall be used or treated as a "personal asset."

(g) Private Insurance Damage Provision (optional). The government is essentially a self-insurer, but should a GSA vehicle be damaged as a result of misconduct or negligence, the government will seek reimbursement through the Financial Liability Investigations or Property Loss (FLIPL) process (previously known as a Report of Survey) IAW AR 735-5. Some private insurance companies carry a provision covering the insured for damages to GSA or other government vehicles. This provision protects the insured when found liable for damages through the FLIPL. It is recommended personnel who expect to possibly operate GSA vehicles at CST contact their insurance agent about this potential coverage.

(h) All personnel operating a 15-passenger van on Fort Knox are required to complete the 15-Passenger Van Driver Improvement Course through their respective brigade prior to arriving. This course is a self-paced instructional program, with a final exam. Upon completion of the instruction and the exam, print out a personalized Certificate of Completion and bring to CST. The certificate is valid for 12 months. The Certificate of Completion must accompany the operator when operating a 15-passenger van on Fort Knox.

(i) GSA vehicles are required to be dispatched every 14-21 days at BLDG 2730-CST Transportation Motor Pool (TMP), this will be tracked by G4, Training Support Division, Transportation Operations. In addition to the TMP dispatch, an internal operator control log and operator maintenance record is maintained by each staff section, committee/Task Force, and company/regiment on a daily basis. These documents are used to monitor operator usage and maintenance throughout CST. The internal operator control log will be collected at each tri-weekly re-dispatching. Please note initial inspections are very important as spare tires and other equipment have been



found missing. Personnel who do not complete initial and daily inspections could be charged for missing equipment.

(j) CST TMP hours of operation are Monday – Friday, 0800-1600 and Saturday 0800-1200 hours. A CST Fleet Manager is assigned to S4 throughout CST and is the POC for vehicle questions, problems or emergencies. Additional vehicle information can be found in the CST SOP. \*Hours are subject to change.

(k) Contractor Vehicle Use. Contract employees participating in CST may utilize GSA vehicles IAW the contract stipulations. The policy and procedures in AR 58-1 apply to all Army owned/leased motor vehicles furnished to DA contractors. Contractors are not protected under the Federal Tort Claims Act (FTCA). Contractors will carry employee vehicle liability insurance. Any cadre contractors involved in a GSA vehicle accident must identify themselves as contractor employees immediately, and then follow corporate procedures for reporting the accident. In case of contractor at-fault GSA vehicle accident/incident at CST, the supporting GSA Fleet Management Center (FMC) charges Cadet Command's Billed Office Address Code (BOAC) Number. When the bill is received, a claim must be filed with the Contract Program Manager (Insurance carrier) to reimburse Cadet Command's BOAC account for GSA vehicle accident/incident repair costs. Mechanical issues resolved while GSAs are being used at CST resulting in a BillBack will NOT be reported as CST "accident" damage.

(l) Prior to turn-in inspection of GSA vehicle, the vehicle needs to be cleaned (inside and out) and topped-off before it will be accepted. Regardless of who operated the vehicle during the time it was at use during CST.

(m) Contractor Vehicle Use. Contract employees participating in CST may utilize GSA vehicles IAW the contract stipulations. The policy and procedures in AR 58-1 apply to all Army owned/leased motor vehicles furnished to DA contractors. Contractors are not protected under the Federal Tort Claims Act (FTCA). Contractors will carry employee vehicle liability insurance. Any cadre contractors involved in a GSA vehicle accident must identify themselves as contractor employees immediately, and then follow corporate procedures for reporting the accident. In case of contractor at-fault GSA vehicle accident/incident at CST, the supporting GSA Fleet Management Center (FMC) charges Cadet Command's Billed Office Address Code (BOAC) Number. When the bill is received, a claim must be filed with the Contract Program Manager (Insurance carrier) to reimburse Cadet Command's BOAC account for GSA vehicle

accident/incident repair costs. Mechanical issues resolved while GSAs are being used at CST resulting in a BillBack will NOT be reported as CST "accident" damage.

### (3) POVs

(a) General. FKKY is a closed post. Expect random vehicle inspections. A picture ID must be presented to enter FKKY.

(b) Operating a POV. To legally operate a motor vehicle in Kentucky, you must have current proof of insurance for the state in which the vehicle is registered, valid state registration and a valid driver's license.

(c) The operation of trail bikes, mini bikes, motorized scooters, pocket bikes, and privately owned ATVs are prohibited on the Fort Knox installation.

(d) Mopeds. The Kentucky State Motor Vehicle Laws prohibit the operation of Mopeds on freeways within the state. A Moped is any motor driven cycle under five horsepower with less than four wheels.

(e) Motorcycles. The following operator requirements apply to Soldiers while operating a motorcycle on Fort Knox. Drivers must have attended a DOD-sponsored motorcycle safety course. Operator and passenger must wear protective equipment; approved helmet, eye protection (shatter-resistant glasses, goggles, or face shield), gloves, long legged pants, long sleeved shirt or jacket, over the ankle boots or shoes, and high visibility reflective over garments (reflective vest) is not required but highly encouraged. If PT belt is used, it is worn diagonally over the shoulder.

(4) Rental Vehicles. While certain individuals will be authorized rental cars during the Planning Meeting and the Terrain Walk, rental cars are not authorized during CST. CST will provide all required transportation assets.

### (5) Utility Terrain Vehicles (UTVs).

(a) UTVs (John Deere Gators) are widely used during CST operations. UTV operators must be licensed and possess a valid OF 346 (U.S. Government Motor Vehicle Operator's Identification Card) IAW AR 600-55, para. 2-1.b., for the specific item of equipment they are operating.

(b) Operators must complete the Recreational Off-Highway Vehicle (ROV) Safety E-Course found at <http://www.rohva.org>. Operators must provide a copy of their

training certificate to CST Transportation cell to operate a UTV. Cadets are not authorized to operate UTVs during any phase of training at CST.

(c) All training will be documented on the Unit Level Logistics System (ULLS) or manually entered on DA Form 348, Equipment Operator's Qualification Record.

(d) UTV operations must be conducted IAW the Cadet Command UTV Safe Operation Policy. This policy lists required Personal Protective Equipment (PPE), such as helmets/kevlar.

e. Travel Order Preparation.

(1) All Cadre travel orders for CST will utilize DTS except for contractors. Contractors will follow the procedures IAW their employment Company. All 2LT going TDY Enroute to BOLC-B to support CST will receive orders through CCIMM; this includes manual DD 1610s (travel orders) as well as PCS orders and any amendments. TDY Enroute travel is not built in DTS.

(2) While air is the preferred mode of travel, Cadre may be authorized to drive a POV to CST, with mileage reimbursement according to JTR, Chapter 2, Para 020210 (eg. Reimbursement not to exceed x1 travel day, reimbursement for rest stop not authorized). For travel over 400 miles one-way or 800 miles roundtrip a Constructive Travel Worksheet (CTW) must be completed and uploaded in the DTS Authorization as a substantiating record. When completing the CTW the traveler will complete CTW Sections 1-3 (all required and applicable transportation costs associated with air travel). In and around TDY location mileage is not authorized.

(3) Cadre must verify the accuracy of the information on CST orders. Note: orders improperly formatted or with incorrect data will be returned to the traveler to be corrected. Once signed by the AO, travelers will receive e-mail notification of approved orders and may execute those orders. Cadet Command G8 will perform a 10% post-audit review on settlement vouchers. Questions concerning DTS should be directed to the Brigade POCs.

(4) As an exception to policy, cadre from Guam, Puerto Rico, America Samoa, and other geographically distant locations are authorized to arrive at CST one day early. Cadre from these locations, choosing this option, must contact the CST Lodging Coordinator ahead of time to ensure billeting is arranged. Failure to coordinate early

arrival with the Lodging Coordinator may result in the cadre member obtaining a room for the night at their own expense. POC for billeting is the CST Lodging Coordinator.

e. Meals. All Soldiers TDY to Fort Knox in support of CST will be under the Essential Unit Messing (EUM).

(1) ROTC Brigades will be responsible for processing payroll deductions through their servicing DMPO for all CST support personnel under EUM.

(2) CAC will be encoded for EUM during CST in-processing to prevent Soldier from having to pay cash for meals consumed in CST DFAC.

(3) In accordance with the JTR, Soldiers are entitled to 75% of their per diem entitlement on travel days.

(4) Directions to FKKY. FKKY is south/southwest of Louisville, KY. FKKY exits are off US 31W which is best accessed from I-65, I-265 or Western Kentucky Parkway. From US 31W, take the Fort Knox Chaffee (Main) gate exit. Have military or government ID card, vehicle registration and proof of insurance available for presentation at the gate if requested. Contact the CST TOC if you have difficulty accessing the installation. Cadre must report to CST G1 for initial in-processing at Copple Center, Building 6590, no later than 1800 on their scheduled CST report date. CST Billeting is open 24 hours a day. Cadre that unavoidably report after 1800 will be billeted overnight, but must return at 0600 the following morning to complete in-processing.

(5) Upon completion of G1 in-processing, cadre are required to report to their CST Task Force Headquarters, or respective staff element, no later than 0800 on the morning following their scheduled report date. Task Force HQ/S1 will maintain accountability of personnel and provide subordinate duty location and team OIC contact information. Personnel will report to locations as follows:

- i. Task Force Leader: Building 6013
- ii. Task Force Warrior: Building 6014
- iii. Task Force Training: Building 1732
- iv. Task Force Tactics: Building 1732
- v. G-1/8: Bldg 6590
- vi. G-3/ CST TOC, Training Management, Legal: Bldg 5924
- vii. CST HQs: Building 5925
- viii. G-4/Safety: Bldg 5932

- ix. G-6: Bldg 5930
- x. PAO & Ceremonies: Bldg 5935
- xi. SHARP: Bldg 5950
- xii. Task Force Medical: Building 5914
- xiii. Task Force Wolf (including AR-MEDCOM): Building 1475
- xiv. Task Force FORSCOM: Building 6546

(6) Airport Information. Commercial airline flights to the FKKY area arrive at the Louisville International Airport (SDF), located approximately 40 minutes north of FKKY. Ground transportation to FKKY will be provided. Upon arrival, claim baggage and proceed to the FKRC, on the airport's ticketing level Personnel should be prepared to obtain transportation to Fort Knox via taxi or ride-sharing service.

(7) Train/Bus Information. It is recommended cadre not use these modes of transportation.

(a) Reporting/In-Processing. All cadre will report to building 6590, Copple Center, for in-processing between 0600-1800 daily on the travel order reporting date. Reporting for in-processing in civilian attire is authorized. 2LT should have ACU readily available for administration of oath on report date. Soldiers who report with physical disabilities which may hinder their performance will be reassigned or returned to unit. If reassigned, the Soldier's departure date may be adjusted.

(b) Cadre must know their TDA-assigned line number and duty assignment when reporting to in-processing.

(c) Cadre must hand-carry the pertinent documents to Copple Center for administrative in-processing (See Appendix F for cadre administrative checklist)

(d) Do not report early! Cadre who report early will be billeted off post at their own expense, regardless of rank. Exception: 1-day early arrivals authorized for cadre personnel traveling from Guam, Hawaii, Puerto Rico, and American Samoa.

f. Billeting.

(1) Cadre billeting is a combination of on-post billeting (barracks or other available quarters), on-post lodging/hotel, or off-post contracted lodging or hotel. G4 will determine best method based upon billeting availability at the time of in-processing.

(a) DAC must make their own hotel arrangements on/or near Fort Knox with their government travel card, and will be reimbursed at the government lodging rate, in accordance with the JTR.

(2) Concept. The primary consideration in assigning cadre billets is to support the CST mission. Billet area/location priority is to the Regiments, committees, and staff respectively, regardless of rank or position.

(a) Regimental cadre are billeted together as close to the Regimental barracks as possible. Committee cadre are billeted with their respective committees and as close to their training sites as possible. Cadre serving on the CST staff are billeted in the remaining available beds.

(b) Due to funding constraints and room availability, personnel may be doubled up in assigned rooms regardless of rank. Rooms have already been designated/reserved by male/female categories. Cadre must be conscious of minimizing personal gear due to the limited square footage and closet space (wall locker) available in each living area. Cadre exceeding reasonable amounts of clothing and personal gear may have those items placed into a storage unit at the cadre members' expense.

(c) Any room assignment discrepancies or issues should be brought to the attention of the S4 during in-processing.

(d) Exceptions to the above instructions must be approved in advance by the CST DCoS.

(3) Pets. Do not bring pets! Pets are not allowed in billeting facilities. Pets brought to CST shall be boarded somewhere else at cadre expense.

g. Travel Camp.

(1) Although discouraged, facilities are available at the FKKY Travel Camp. However, cadre bringing a recreational vehicle or trailer must make reservations 90 days in advance with the FKKY Travel Camp. Reservations are accepted on a first come, first serve basis and can be renewed on a case-by-case basis with the manager's office.

(2) After obtaining confirmed reservations notify the CST Billeting Office.

h. Family. ***Do not*** bring Family members. TDY is provided for the cadre member only. Cadre bringing Family members to CST must make personal arrangements for housing accommodations somewhere else at their expense. Transient housing facilities are allocated on a space available basis, but personnel in a Permanent Change of Station (PCS) or school status use these heavily during the summer months. Family members shall not billet in Bachelor Officer/Enlisted Quarters (BOQs) or (BEQs).

i. Reserving Your Room.

(1) Late Arrivals. Late arrivals must be approved through TF Commanders by the CST Commandant through the TDA manager. Those personnel arriving late will be considered to be in an unauthorized leave status. If you know you will arrive later than indicated on your orders, notify the TDA manager immediately.

(2) Extensions. Cadre extended beyond their planned departure date on the TDA must notify their Chain of Command to work with the S4 to ensure their room reservation is extended.

j. Departing from CST.

(1) All cadre must out-process through Bldg 6590, Copple Center, no earlier than 0600 on the scheduled CST departure date.

(2) No cadre member shall depart early without an early release form signed by the CST Commandant, or his designated representative (Deputy Commandant or CoS), in accordance with CST AD-SOP.

(3) All cadre must coordinate out-processing with CST S-1 during normal duty hours (0600-1800).

(4) Cadre are sometimes required to serve in a duty requirement (Cadet Board, involved with a 15-6 or FLIPL, etc) which could extend their TDY. If this occurs, both CST Lodging Coordinator and the G-1 must be notified. Cadre should not commit to outside events immediately following anticipated departure date; allow for flexibility in the event of an unanticipated extension.

(5) Release from CST.

(a) The TF Chain of Command or designated representative will release cadre to out-process through the Copple center from assignment upon completion of

duties, or direct cadre reassignment not earlier than 24 hours before graduation and at least 24 hours after graduation within the assigned section. Cadre will be notified in advance if any reassignments are projected.

(b) 2LT out-processing is conducted IAW CST SOP. Additionally, 2LT are required to complete TDY settlement and other paperwork up to three (3) days prior to departure.

k. Appearance/Equipment.

(1) Uniforms.

(a) The standard duty uniform for cadre is the OCP with appropriate patches and accoutrements/insignia (all subdued); with patrol cap. Beret will be worn during ceremonies and other prescribed events (Select Personnel). All regimental cadre will bring beret.

(b) All cadre will bring at least one complete set of the APFU (black and gold). The set includes T-shirt, shorts, jacket, pants, and reflective safety belt. The reflective safety belt must be worn at all times while running on Fort Knox regardless of the time of day – bring from home-station. When wearing T-shirt and shorts, wear the belt around the waist; when wearing the jacket, wear the belt diagonally over the right shoulder.

(c) Cadre and Military Institutional Representatives (MIRs) who are required to attend the Cadet Command CLE Buffet Social must bring Civilian casual dress attire (slacks, khakis, collared shirt, and polo shirt with school name/emblem).

(d) DA Civilian dress code for CST is in accordance with USACC Employee Handbook and USACC Dress Code Policy, dated 7 September, 2018. Employees who participate in field training should wear durable casual weather/terrain appropriate clothing and recommend durable hiking boots.

(2) Equipment. All cadre assigned to a committee or a regiment **MUST** report to CST with the outlined in the USACC packing lists.

(3) PPE, such as Helmet Ground Troops Parachutists, or ACH is required for wear while operating or riding in Army Tactical Vehicles.



(4) Limited quantities of selected reference materials are available at FKKY for use during CST. Cadre must bring any references they desire for personal use from their home-station.

I. Physical Conditioning.

(1) Cadre are required to bring the PFU IAW AR 670-1 with reflective belt.

(2) Staff and cadre must maintain good physical condition, meet height/weight standards, and be prepared to take an ACFT.

m. MWR.

(1) Laundry. Commercial laundries, which provide fast service, are available at your own expense. Barracks facilities have washers and dryers installed. Additionally, laundromats are available in nearby communities.

(2) Postal. Complete postal services are available at the main Fort Knox Post Office.

(3) Recreation. FKKY has on-post theaters, bowling lanes, service clubs, libraries, craft shops, tennis courts, swimming pools, gymnasiums, and an 18-hole golf course. Additionally, there are fishing and boating facilities. These facilities are available upon presentation of proper identification and payment of fees, where applicable. Cadre must comply with all regulations concerning licenses and safety. Boat rentals require boat safety certification. Golfers may join the golf club at a reduced rate for their length of stay at FKKY.

(4) Clubs. The Saber and Quill and the Sam Adams Brew House offer both casual and formal atmospheres. The clubs permit the duty uniform or casual civilian attire. To cash checks at the clubs, you must have your military ID card.

(5) DA Civilians in a TDY status are authorized to make purchases at AAFES establishments. Personnel without a valid DD Form 1173 directing exchange privileges, must have "Exchange Privileges Authorized" included in the remarks section of travel orders and will not be authorized to purchase alcohol or tobacco products. All civilians are authorized to use the food facilities and purchase single meal consumables in the Express stores.

(6) Tobacco/Alcohol Control Plan. Army policies permit smoking in designated areas only. Smoking or use of any tobacco product within sight of Cadets or on committee sites during training is prohibited. Smoking or use of tobacco products in buildings used as offices, workplaces, or billets is prohibited.

(b) Tobacco cessation policy for CST.

(i) Cadre are prohibited from using tobacco products in areas where Cadets are likely to observe use (for example, in the brigade, regiment, company, or any training area).

(ii) All Cadets are prohibited from purchasing/using tobacco products while attending CST.

(c) Instruction on the adverse impact of tobacco use on health and readiness is presented to Cadets.

(d) This policy does not cancel or supersede other instructions where smoking is controlled because of fire, explosive, or other safety considerations.

(7) Cadre may possess and consume alcohol in moderation in cadre billets. All cadre will comply with USACC and CST policies related to alcohol consumption.

n. Security of Personal Property.

(1) Weapons. **DO NOT BRING WEAPONS, AMMUNITION or EXPLOSIVES** of any type to CST. CST does not have the provisions to properly store Privately Owned Weapons (POWs).

(2) Second Lieutenants supporting the CST mission enroute to their assigned BOLCs are authorized to bring privately owned weapons, if they have no alternate storage options. All firearms must be declared upon entry onto Fort Knox and Weapons Registration Permit verified when entering the ACP. Second Lieutenants must register their firearm prior to attending CST on FK FORM 2759, dated JUN 2015. Their PMS can sign the form as their commander. When declaring a firearm at the point of entry, all personnel will pull directly to the guard booth for processing. All firearms must be unloaded and properly stored. Privately owned firearms carried in a vehicle will be secured in the trunk. For vehicles without a trunk, firearms will be encased in a container. Carrying concealed personal firearms on Fort Knox is strictly prohibited. State concealed weapons permits are not recognized or honored on the installation. Personal

weapons will be stored in CST arms room and access to weapons will not be available until departure from mission.

(3) Personal Property. Cadre are responsible for the security of their personal property. Do not bring large amounts of money, jewelry, or any unnecessary high dollar value items.

### **5-3. Safety.**

a. General. Military training is designed to be tough and realistic. This training can also be hazardous to Cadets and Cadre. Applying the Risk Management Process in all phases from planning to execution can significantly mitigate potential hazards or decrease the severity of the injury.

b. Injury Prevention. CST cadre provide specific guidance regarding safety and injury prevention throughout the training cycle. Dehydration, heat exhaustion, heat injury, heat stroke, lightning strikes, insect bites/stings, allergies, and reactions to poisonous plants are just a few of the health problems you may encounter. Cadre or Cadets with known medical problems will provide appropriate information to the respective university PMS and Army medical personnel. Heat is a major hazard during CST. The temperature and humidity are contributing factors to potential heat injuries. Cadre will ensure they review the heat mitigation measures in the CST Policy Memorandum 8: Guidelines for Evaluation and Treatment of Casualties with Potential Heat Illness developed by the USACC Surgeon Office. Development and utilization of the Deliberate Risk Assessment Worksheet (DRAW) for each event will assist in identifying hazards and developing controls measures to prevent or reduce the severity of mishaps.

c. Lightning Protection Systems/Areas (LPS/LPA) facilities are in use through most of the Fort Knox training areas. All personnel will review the CST TOC Severe Weather Tiers. Cadre will become familiar with the locations of LPS/LPA within their areas, the number of personnel the LPS/LPA can support and the protection it provides. Cadre and/or Cadets will not be in the training area without information on the nearest LPS/LPA shelter or the availability of a vehicle and direct communications with TOC or range control. Cadre working at TOC locations will be familiar with CST TOC Severe Weather Tiers, weather forecast information and how to get the information out to the Task Forces as rapidly as possible.

d. **Poisonous Plants and Animals.** Cadre and Cadets must learn to recognize and avoid poison oak, poison sumac, and poison ivy as all are present in the Fort Knox training areas. Animals are everywhere during CST. Do not interact with the local domesticated or wild animals.

1. Do not approach or handle animals or insects.
2. Do not feed or shelter animals in or around the unit area.
3. Keep your area clear of trash as this may attract animals.

Everyone will review the CST Local hazards briefing located on the USACC Safety SharePoint.

e. **Safety Goggles/Glasses.** Eye protection is required whenever eye injury hazards exist, i.e., firing ranges, Land Navigation, training area, or areas with blowing debris. Cadets will not wear contacts during CST IAW: AR 40-63 Ophthalmic Services, para 4-4c(1), AR 670-1 Chap 3-10b and Section 7 of the CST AC and BC Cadet Welcome packet. Cadre must bring UVEX eye protection for CST.

f. **Hearing Protection.** Earplugs are required whenever hazardous noise levels are known or suspected (i.e., firing ranges and areas where noise levels are deemed hazardous, especially where signs are posted). Ear plugs will be provided to cadre and to be carried/used when required

g. **Cadre/Cadets with Prior Illness or Injury.** Cadre and Cadets with identified medical issues will be issued color- coded beads and/or zip ties to denote certain safety issues. These beads/strips will be fastened to the cadre boot laces and PT shoes for easy visual identification. The S4 will maintain a supply of color-coded beads. Regimental and Committee leadership are responsible for ensuring Cadre and Cadets have the correct beads and are worn. The colors represent:

- (1) RED: Previous hot weather injury
- (2) WHITE: Previous cold weather injury
- (3) BLUE: Weak Swimmer
- (4) YELLOW: Bee Allergy

(5) GREEN: All other Allergies

h. Mishap Reporting Procedures.

(1) All mishaps/incidents will be reported the CST Task Force or Regimental safeties. The safeties will provide guidance on the necessary forms that will need to be submitted to the CST Safety office.

(2) All mishaps/incidents to GSA vehicles will be reported immediately to the CST Motorpool. The driver will report the mishap/incident to their immediate supervisor, CST TOC, CST S4 and CST Safety within 24 hours IAW CST Policy memo 12 - GSA Guidance developed by USACC G4.

i. Mishap Prevention.

(1) Everyone has responsibility to prevent mishaps. Safety is a leadership responsibility and all are equally responsible for ensuring training areas and equipment are used safely. Common sense, close supervision, risk management, and utilization of the Deliberate Risk Assessment Worksheet (DRAW) will help mitigate or reduce the severity of an injury.

(2) Range Certification. Cadre, OICs and Range Safety Officers (RSOs), who operate range complexes must be certified IAW Fort Knox Regulation 385-22, Range Regulation (Training/Impact Areas). The regulation can be accessed at the following website: <http://www.knox.army.mil/Garrison/dhr/asd/docs/regs/R385-22.pdf>. The POC for this action is CST TOC.

## **APPENDIX A – References**

### **USACC REG 145-3**

Pre-commissioning Training and Leadership Development

### **USACC CST Policy Memorandums**

Cadre-Student Relationships

### **DODFMR 7000.14-R, Volume 7**

Department of Defense Financial Management Regulation

### **AR 5-9**

USACC CIRCULAR 145-5, 12 October 2021

---

Intra-service Support Installation Area Coordination with FORSCOM/TRADOC  
Supplement 1

**AR 15-6**

Procedures for Investigating Officers and Boards of Officers

**AR 27-10**

Military Justice

**AR 27-20**

Claims

**AR 30-22**

The Army Food Program

**AR 37-104-4**

Military Pay and Allowances Policy and Procedures - Active Component

**AR 40-3**

Medical, Dental, and Veterinary Care

**AR 40-501**

Standards of Medical Fitness

**AR 58-1**

Management, Acquisition, and Use of Motor Vehicles

**AR 145-1** Senior ROTC Program: Organization, Administration, and Training

**AR 210-130**

Laundry and Dry Cleaning Operations

**AR 335-15**

Management Information Control System

**AR 600-9**

The Army Body Composition Program

**AR 600-20**

Army Command Policy

**AR 601-210**

Regular Army and Army Reserve Enlistment Program

USACC CIRCULAR 145-5, 12 October 2021

**AR 735-5**

Policies and Procedures for Property Accountability

**CC Reg 145-3**

Army Senior Reserve Officers' Training Corps (ROTC) Basic Officer Leader Course- A (BOLC-A)—On-campus Training and Leadership Development

**CC Reg 385-10**

Command Safety

**CC Reg 670-1**

Uniform Wear and Appearance

**CC PAM 145-1**

ROTC Incentives Procedures

**CC Pam 145-4**

Enrollment, Retention and Disenrollment Criteria Policy and Procedures

**CC PAM 145-9-1**

Cultural Awareness Training Program

**Fort Knox Regulation 210-52**

Basic Standards of the Human Resource Center of Excellence and Fort Knox

**Fort Knox Regulation 385-22**

Range Regulation (Training/Impact Areas)

## **APPENDIX A-1. Glossary**

### **ABBREVIATIONS**

AAC	Accident Avoidance Course
AC	Advanced Camp
AAR	After Action Review
ACH	Army Combat Helmet
ACU	Army Combat Uniform
ADOS	Active Duty Operational Support
AD-PDT	Active Duty for Professional Development Training
AEO	Alternate Entry Option
AMC	Accident Management Center
ACFT	Army Combat Fitness Test
APP	Appendix
AR	Army Regulation
ARC	American Red Cross
ARNG	Army National Guard
ASU	Army Service Uniform
AT/FP	Anti-Terrorism/Force Protection
ATP	Advanced Travel Payment
ATV	All-Terrain Vehicle
AUP	Acceptable Use Program
BAS	Base Allowance for Subsistence
BC	Basic Camp
BEQ	Bachelor Enlisted Quarters
BOAC	Billed Officer Address Code
BOLC	Basic Officer Leaders Course
BOQ	Bachelor Officer Quarters
BPFT	Basic Physical Fitness Test
BRM	Basic Rifle Marksmanship
CAC	Common Access Card
CBRN	Chemical, Biological, Radiological, Nuclear
CCIMM	Cadet Command Information Module
CCFA	Cadet Command Fitness Assessment
CELTT	Cadet English Language Training Team

USACC CIRCULAR 145-5, 12 October 2021



g

CIF	Central Issue Facility
CLE	Community Leader/Educator
COER	Cadet Officer Evaluation Report
COERSF	Cadet Officer Evaluation Report Support Form
CPD	Cadet Personnel Division
CPDT	Cadet Professional Development Training
CPFT	Cadet Professional Field Training
CSD	CCWP Support Detachment
CST	Cadet Summer Training
CTLT	Cadet Troop Leader Training
CTO	Commercial Travel Office
CCWP	Cultural Understanding and Language Proficiency Program
DA	Department of the Army
DAC	Department of Army Civilian
DAP	Developmental Action Plan
DODMERB	Department of Defense Medical Evaluation Review Board
DFAC	Dining Facility
DFAS	Defense Finance and Accounting Service
DS	Drill Sergeant
DTS	Defense Travel System
EFT	Electronic Fund Transfer
EOCC	End of Course Commissionees
FDA	Food and Drug Administration
FLIPL	Financial Liability Investigation or Property Loss
FKKY	Fort Knox, Kentucky
FKRC	Fort Knox Reception Center
FMC	Fleet Management Center
FOT	Follow-On Training
FRG	Family Readiness Group
FTCA	Federal Tort Claims Act
FY	Fiscal Year
GORP	Get Odometer Reading at Pump
GOV	Government Owned Vehicle
GSA	Government Services Administration

USACC CIRCULAR 145-5, 12 October 2021

GTG-AD	Green to Gold-Active Duty
GUTC	Government Unit Travel Card
HIV	Human Immunodeficiency Virus
HOR	Home of Record
HRA	Human Resource Administrator
HT	Height
HTR	Hometown Recruiter
IAW	In Accordance With
ID	Identification
IG	Inspector General
APFU	Approved Physical Fitness Uniform
JIIM	Joint, Interagency, Intergovernmental, and Multinational
JTR	Joint Travel Regulation
LCP	Leader Certification Program
LD	Line of Duty
LDP	Leader Development Program
LDRB	Leader Developmental Review Board
LES	Leave Earning Statement
LNO	Liaison Officer
LOG	Logistics
LPS	Lightning Protection System
LREC	Language Regional Expertise and Culture
MCLX	Mission Context Leadership Exercise
MEDOPS	Medical Operations
MIR	Military Institutional Representative
MMR	Measles, Mumps, Rubella
MOA	Memorandum of Agreement
MOI	Memorandum of Instruction
MOU	Memorandum of Understanding
MTR	Master Training Reference
MWR	Morale Welfare and Recreation
NCOER	Noncommissioned Officer Evaluation Report
NDEA	Non-DTS Entry Agent
NET	Not Earlier Than
NLT	Not Later Than

USACC CIRCULAR 145-5, 12 October 2021

NOK	Next of Kin
NSTP	Nurse Summer Training Program
NTV	Non-Tactical Vehicle
OC	Officer Candidate
OCP	Operational Camouflage Pattern
OER	Officer Evaluation Report
OIC	Officer in Charge
OTC	Over-The-Counter
OVM	Operational Vehicle Maintenance
PAO	Public Affairs Office
PCS	Permanent Change of Service
PMS	Professor of Military Science
POC	Point of Contact
POV	Privately Owned Vehicle
POW	Privately Owned Weapons
PPE	Personal Protective Equipment
PRT	Physical Readiness Training
PT	Physical Training
PX	Post Exchange
RAB	Regional Affiliation Brief
RAC	Regimental Action Ceremony
ROV	Recreation Off-Highway Vehicle
RSO	Range Safety Officer
RTO	Regimental Training Officer
SDAP	Special Duty Assignment Pay
SDF	Louisville International Airport
SGLI	Service Members' Group Life Insurance
SIFT	Selection Instrument for Flight Test
SJA	Staff Judge Advocate
SMP	Simultaneous Membership Program
SNA	Statement of Non-Availability
SOFA	Status of Forces Agreement
SOP	Standard Operating Procedure
SRP	Soldier Readiness Processing
SSN	Social Security Number

USACC CIRCULAR 145-5, 12 October 2021

---

STX	Situational Training Exercise
TBP	To Be Published
TDA	Table Of Distribution and Allowance
TDY	Temporary Duty
TF	Task Force
TMC	Troop Medical Clinic
TMP	Transportation Motor Pool
TOC	Tactical Operation Center
TRIPS	Travel Risk Planning System
UCMJ	Uniformed Code of Military Justice
UMT	Unit Ministry Team
USAR	United States Army Reserve
UTV	Utility Terrain Vehicle
WT	Weight

# APPENDIX B Example of CST TASK ORG



## CST Task Organization

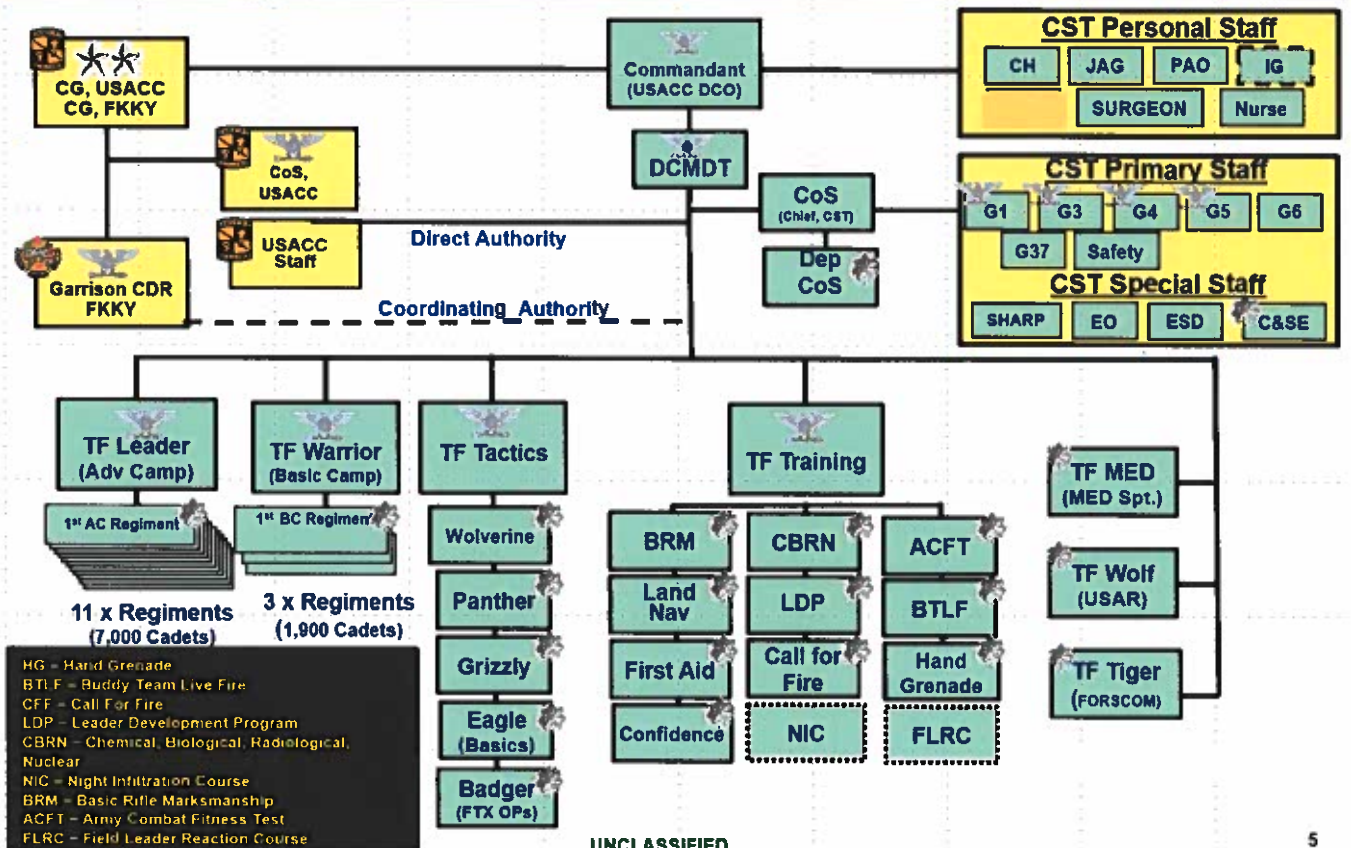

HG - Hand Grenade  
 BTLF - Buddy Team Live Fire  
 CFF - Call For Fire  
 LDP - Leader Development Program  
 CBRN - Chemical, Biological, Radiological, Nuclear  
 NIC - Night Infiltration Course  
 BRM - Basic Rifle Marksmanship  
 ACFT - Army Combat Fitness Test  
 FLRC - Field Leader Reaction Course

UNCI ASSIFIFO

## **APPENDIX C-Cadet Records and CCIMM Checklist**

### **1. Document Preparation Guidance for Cadet Record Items**

a. Information Regarding DD Form 93, Record of Emergency Data. Pending IPPS-A guidance.

(1) Completed form is valid for one year from completion of Training and must be uploaded into iPERMS account via CCIMM.

(2) Aliens are not required to complete item 9.

(3) Advise Cadets to carefully consider designating NOK because this is the person initially notified in the event of death or serious injury/illness. Cadets must ensure all information provided for their next of kin is current and accurate. Record the NOKs name and complete telephone number in item 13.

(4) Ensure the information entered on DD Form 93 matches data entered on the SGLI/NOK Validation Document.

b. Information regarding SGLV Form 8286, Servicemen's Group Life Insurance Election.

(1) All eligible Cadets (except aliens) attending CST are automatically issued the maximum of \$400,000 SGLI while attending CST, and while proceeding directly to and from FKKY under orders issued by competent authority. Cadets receive full coverage (\$400,000) unless the Cadet desires to waive SGLI or be insured for a lesser amount. Cadets attending CST who do not decline SGLI coverage will automatically have premiums withheld from their CST pay, unless they are Simultaneous Membership Program (SMP) participants, who are already having SGLI premium deductions withheld from their Reserve Component pay.

(2) Cadets not declining SGLI coverage must pay the monthly cost of coverage, whether coverage is for one day or the entire month. Insurance in force at the time of completion or termination of an individual's stay at CST or conclusion of CTLT will remain in force until the completion of the month. If the Cadet is on orders for 31 days or more, the coverage continues for 120 days after the orders end, free of charge.

(3) All Cadets, except aliens, are required to complete this form and submit it to iPERMS via CCIMM prior to training. If the Cadet desires to change the form, the change must be entered into CCIMM for the information to reach DFAS. Exercise care in completion of this form since it will become effective should death or serious injury occur while a Cadet is enroute to or from FKKY or while attending CST. Ensure strict

USACC CIRCULAR 145-5, 12 October 2021

compliance with the provisions of AR 600-8-1, Government Life Insurance, SGLI Veterans Group Life Insurance, U.S. Government Life Insurance and National Service Life Insurance, Para 11-30, which requires the rights, benefits, and privileges under SGLI be explained to all Cadets prior to completion and during review of the form.

(4) SMP participants, who are presently covered by SGLI with premium deductions being withheld from their drill pay will not be charged additional SGLI premiums while attending CST.

c. Cadets not electing SGLI coverage, must annotate the SGLV Form 8286, in his/her own handwriting; "I want no insurance."

<b>CST CADET PERSONNEL RECORDS CHECKLIST</b>			
CADET NAME (LAST, FIRST, MIDDLE NAME, NAME EXTENSION):			HOST SCHOOL:
The following documents must be hand-carried to CST by <u>ALL</u> Cadets. Any incomplete or incorrect packets will cause delay at in-processing and may negatively impact the Cadet's ability to start training.			
INITIAL	QTY	DOCUMENT	REMARKS
	2	DAMPS Active Duty for Training orders TDY Orders for GTG-AD(for each scheduled training event)	
	1	DD Form 2983, Recruit/Trainee Prohibited Activities Acknowledgement	Must be signed within one calendar year of CST graduation date
	1	Follow-On Training documents (copy of orders and travel itinerary etc), as applicable	Type: Location:
	1	Travel Itinerary and 1610, including all legs of travel	Do not schedule flights for prior to 1500 EST on graduation day.
	1	Valid Common Access Card (CAC) with known PIN (ALL Contracted Cadets)	A new CAC is required if expiration date is within 60-days of CST report date. Fort Knox does not waiver the DoD proof of identification requirements for replacement CAC while in training. Ensure Cadets travel with 2 forms of valid identification
	1	Valid government-issued photo ID (non-contracted Cadets)	
	1 set	Identification Tags	All Contracted Cadets
	1	DD Form 93	Must be signed within one year from completion of training and a copy uploaded into iPERMS via CCIMM, prior to reporting to CST
	1	SGLV Form 8286 (Servicemembers' Group Life Insurance Election and Certificate)	Signed form must be uploaded into iPERMS via CCIMM prior to reporting to CST. Contracted Cadets only.
	1	Verify all bank and accounting information in CCIMM	Student/Cadet Information/Pay Tab
	Optional	Early Release Request (if applicable)	Requests for Cadet Early Release will be approved by CST TF Commander
HRA NAME, PHONE NUMBER AND EMAIL ADDRESS:			

**Figure 1-D. CST Cadet Personnel Record Checklist**

## CONSENT FOR MEDICAL AND DENTAL CARE OF MINOR

Name of Cadet: \_\_\_

Social Security Number: \_\_\_\_\_

School: \_\_\_

Occasionally, a Cadet will require medical or dental care while at Fort Knox. Except in an emergency, a doctor or dentist cannot provide treatment without first obtaining consent from an authorized individual. In the case of a Cadet under the age of 18, authorized individuals include parents, guardians, and persons designated by a parent or guardian. As the parent or guardian of a Cadet under the age of 18, please tell us how we can contact you to obtain consent in the event your child requires medical or dental care.

Names of Parents/Guardians:

\_\_\_\_\_

Address (es) of Parents/Guardians:

\_\_\_\_\_

Telephone Number(s) of Parents/Guardians:

\_\_\_\_\_

## MEDICAL POWER OF ATTORNEY

You may authorize your child, or any adult, to act in your place and give consent for medical or dental treatment. If you wish to do so, please check the appropriate box (es) below and complete the remainder of this form. You will need to have your signature notarized.

I authorize \_\_\_\_\_ (name of Cadet) to consent to medical or dental care for himself or herself. I certify he or she is at least 16 years of age.

I authorize

\_\_\_\_\_ (name, address, and telephone number of third party) to consent to medical or dental care. I certify this individual is at least 18 years of age.

The person(s) named above is (are) authorized to consent to any and all medical and dental treatment deemed necessary by a duly licensed physician or dentist, and to execute any consent required by medical or dental authorities incident to the provision of medical, surgical, or dental care to Cadet \_\_\_\_\_. I authorize the person(s) named above to perform any and all acts, deeds, and things whatsoever as fully and effectually as I might and could do in my own person if personally present. I do hereby ratify and confirm each of the lawful acts of the person(s) named above. I intend for this to be a Durable Power of Attorney, which shall continue to be effective if I become disabled, incapacitated, or incompetent. Unless sooner revoked or terminated by me, this document shall become null and void on \_\_\_\_\_. (This document may be valid for up to three years.)

Date \_

Parent or Guardian X \_\_\_\_\_

USACC CIRCULAR 145-5, 12 October 2021



**NOTARIZATION**

**CONSENT FOR MEDICAL AND DENTAL CARE OF MINOR**

Name of Cadet: \_\_

Social Security Number: \_\_\_\_\_

School: \_\_\_\_\_

State of \_\_

County of \_\_

I, the undersigned, certify I am a duly commissioned, qualified, and authorized notary public. Before me personally, within the territorial limits of my warrant of authority, appeared Grantor, who is known to me to be the person who is described herein, whose name is subscribed to, and who signed this Power of Attorney as Grantor, and who, having been duly sworn, acknowledged this instrument was executed after its contents were read and duly explained, and such execution was a free and voluntary act and deed for the uses and purposes herein set forth.

In witness whereof, I have hereto set my hand and affix my official seal on  
\_\_.

X \_\_\_\_\_ My Commission Expires: \_\_\_\_\_ Notary Public

**CONSENT FOR MEDICAL AND DENTAL CARE OF MINOR**

**Privacy Act Statement**

1. **AUTHORITY:** The authority for the collection of personal information is 10 United States Code Section 3013.

2. **PRINCIPAL PURPOSE:** The purpose for soliciting this information is to determine those persons possessing legal authority to consent for medical and dental care for Cadets under the age of 18.

3. **ROUTINE USES:** Any information you disclose can be provided to members of the Department of the Defense who have a need for this information in the performance of their official duties. In addition, any information may be disclosed to the U.S. Department of Justice when necessary in the defense of litigation brought against the Department of Defense or against members of the agency as a result of actions taken in their official capacity.

4. **DISCLOSURE MANDATORY OR VOLUNTARY – THE EFFECT OF NOT PROVIDING INFORMATION:** Providing the information is voluntary. There is no adverse effect to you for not furnishing the information. However, the failure to provide information may result in the denial of, or a delay in furnishing, no emergency medical or dental care to Cadets under the age of 18.

---

**Figure 2-D. CONSENT FOR MEDICAL AND DENTAL CARE OF MINOR**

---

## **APPENDIX D - CST Medical Records**

### **INFORMATION PAPER**

Subject: Cadet Summer Training DD Form 2807-1.

1. Purpose: To provide information on how to fill out DD Form 2807-1 for Cadet Summer Training

2. Facts:

a. Background. Cadet Summer Training (CST) physicals historically used varying paper forms and mailed documents between institutions. The Army has directed reduction in paper usage and costs and increase in permanent filing of documents. To meet these changes in 2015 CST converted to fillable PDF forms and the use of a HIPPA compliant SharePoint site.

b. The mandatory electronically fillable DD Form 2807-1 along with all CST medical forms are provided on the medical records SharePoint site under "CST 19 Required Documents."

<https://army.deps.mil/army/cmds/USACC-CST-Medical/default.aspx>

c. Instructions for DD Form 2807-1

(1) Fill-in blocks 1-4 utilizing the day completed in block 3.

(2) Blocks 5 and 6a are already completed.

(3) Block 6.c, select "Commissioning" or "Other" and fill in "Flight" for cadets approved to receive a flight physical at CST.

(4) Block 7.a. use Military Science (MS) year number (i.e. MSIII). If Simultaneous Membership Program (SMP) or Green to Gold (G2G), include current enlisted rank and component. If civilian, leave blank. Block 7b leave blank.

(5) Block 8 annotate any medications, herbal supplements, vitamins, and over the counter medications. Then in block 29, write the additional information of Medication name, dose, and condition requiring the medication, start date (year and month): OR STATE NONE.

(6) Block 9, list any allergies with a note in block 29 of the reaction to those allergens. I.e. hives, shortness of breath, diarrhea, vomiting, or my mom told me.

USACC CIRCULAR 145-5, 12 October 2021

(7) Blocks 10-28, answer yes if at any time in your life you had these conditions. Block 18 is for females only. For any yes answers explain in Block 30.a. If yes and addressed in DODMERB then write "See DODMERB PE" and state current status of the condition (resolved without issues, resolved with the following limitations, stable with explanation of what made it stable and if unstable explain). If new since DODMERB PE, give a short description of the condition with age, when it started, end date if applicable, treatment, sequelae (i.e. I cannot run), explanation of medications used if not listed under block 8, provider name and or hospital, and current status of the condition (i.e. resolved, resolving, stable, unstable). Sample: 15.c. See DODMERB PE has resolved without any limitations. Another sample: 12.h. At age 20 I sprained my left ankle while running was treated with Motrin and ice by Dr Beaumont, I do not recall the dates, but resolved in less than 6 months without any issues, I continue to participate in basketball, softball and track without any ankle issues.

d. The DD Form 2807-1 is provided on the medical records SharePoint site in digital fillable PDF format with the ability to sign the form digitally and should be processed per the regulations, policies and circulars.

e. DO NOT sign the DD Form 2807-1.

f. The DD Form, 2807-1 will be loaded in the Cadets electronic folder in the CST medical records sharepoint.

g. Instructions detailing processing of CST medical records in sharepoint will be addressed in an annual FRAGO to the CST OPORD.

h. Only the Cadet can fill out the DD Form 2807-1.

CST MEDICAL RECORD CHECKLIST			
NAME (LAST, FIRST, MI):		HOST SCHOOL:	
<p>The following documents must be electronically filled out; exceptions are DODMERB physical and Shot records which must be scanned in PDF format. All documents must be uploaded to CST Medical Records SharePoint.</p> <p>Use the following Naming convention: CADET LAST NAME, CADET FIRST NAME MI, Last Four SSN, Document Name. I.E. Smith, Jane L 1111 DD 2808. Place a check mark on the left side of each required document once complete and uploaded into SharePoint.</p> <p>Any incomplete or incorrect packets will delay Cadets Medical clearance to attend CST.</p>			
QTY	DOCUMENT	REMARKS	
1	Registration	Form needed to create electronic medical record.	
1	DD Form 2807-1	Fill out PDF version electronically. Report of Medical History (3 page form); Complete items 1 - 29, pages 1 & 2; Complete name and SSN on page 3. <a href="https://army.daps.mil/army/casdb/USACC-CST-Medical/default.aspx">https://army.daps.mil/army/casdb/USACC-CST-Medical/default.aspx</a>	
1	DD Form 2808	Fill out PDF version electronically. Report of Medical Examination (3 page form); Complete items 1 - 16. Name and SSN automatically populates on page 2 and 3. <a href="https://army.daps.mil/army/casdb/USACC-CST-Medical/default.aspx">https://army.daps.mil/army/casdb/USACC-CST-Medical/default.aspx</a>	
1	DODMERB Physical	DD form 2351 and DD form 2492 (SMP MEPS PE with DODMERB Qualified stamp). Cadet's <b>ENTRANCE</b> medical examination; Include initial medical consultation and tests, evaluated for entry into the ROTC Program; Include a copy of any subsequent medical examinations.	
1	Shot Records or DD2766	PDF format. Provider/clinic completed document only. Only SMP/G2G may use DD 2766 from MEDPROS. <a href="https://medpros.meds.army.mil/MEDPROSNew/default.aspx">https://medpros.meds.army.mil/MEDPROSNew/default.aspx</a>	
1	DD Form 2005	Privacy Act Statement - Health Care Records. Administrative information must be typed the information: name in signature block, may only use last four of SSN, and date signed. Most likely will have to pen sign. <a href="http://www.dtic.mil/whs/directives/finms/tb/dfbforms2000-2499.htm">http://www.dtic.mil/whs/directives/finms/tb/dfbforms2000-2499.htm</a>	
As Req'd	Medical Waiver	MUST provide proof of approved waiver for a medical disqualification. DODMERB letter and USACC memo	
As Req'd	Memorandum For Record	For Cadets whose medical examinations have been lost, misplaced, destroyed, etc.	
As Req'd	Cadet Command form 131-R	Only for medical waivers and determinations not already in progress.	
As Req'd	Other Medical Documentation	Include all medical documentation generated since the Cadet's initial physical. Flight physical (FP) requests	

Figure 3-E. CST Medical Record Checklist

USACC CIRCULAR 145-5, 12 October 2021

## Cadet Mini-Registration

Please type your response in the provided fields. Date \_\_\_\_\_

Cadets Last name \_\_\_\_\_ First name \_\_\_\_\_ Middle name \_\_\_\_\_

Social Security # \_\_\_\_\_ Gender  M  F

Date of Birth (DD/MM/YYYY) \_\_\_\_\_

Street Address \_\_\_\_\_

City \_\_\_\_\_ State \_\_\_\_\_ ZIP \_\_\_\_\_

Telephone (Home) \_\_\_\_\_ (Cell) \_\_\_\_\_

Host School \_\_\_\_\_ FICE CODE \_\_\_\_\_

School HRA Telephone \_\_\_\_\_

School \_\_\_\_\_

City \_\_\_\_\_ State \_\_\_\_\_ ZIP \_\_\_\_\_

SMP Unit Name \_\_\_\_\_ UIC \_\_\_\_\_

SMP Unit POC & Telephone \_\_\_\_\_

SMP Unit Street Address \_\_\_\_\_

SMP City \_\_\_\_\_ State \_\_\_\_\_ ZIP \_\_\_\_\_

Are you a Service Member  Yes  No If yes, Army  Regular  Reserves   
National Guard.

Are you a Dependent of a Service Member  Yes  No

If yes: Sponsor's Social Security # \_\_\_\_\_

List known allergies and reaction:  None \_\_\_\_\_

\_\_\_\_\_  
\_\_\_\_\_

Figure 4-E. Cadet Mini-Registration

<b>PRIVACY ACT STATEMENT - HEALTH CARE RECORDS</b>		
<i>THIS FORM IS NOT A CONSENT FORM TO RELEASE OR USE HEALTH CARE INFORMATION PERTAINING TO YOU.</i>		
1. AUTHORITY FOR COLLECTION OF INFORMATION INCLUDING SOCIAL SECURITY NUMBER (SSN) Sections 133, 1071-87, 3012, 5031 and 8012, title 10, United States Code and Executive Order 9397.		
2. PRINCIPAL PURPOSES FOR WHICH INFORMATION IS INTENDED TO BE USED  This form provides you the advice required by The Privacy Act of 1974. The personal information will facilitate and document your health care. The Social Security Number (SSN) of member or sponsor is required to identify and retrieve health care records.		
3. ROUTINE USES  The primary use of this information is to provide, plan and coordinate health care. As prior to enactment of the Privacy Act, other possible uses are to: Aid in preventive health and communicable disease control programs and report medical conditions required by law to federal, state and local agencies; compile statistical data; conduct research; teach; determine suitability of persons for service or assignments; adjudicate claims and determine benefits; other lawful purposes, including law enforcement and litigation; conduct authorized investigations; evaluate care rendered; determine professional certification and hospital accreditation; provide physical qualifications of patients to agencies of federal, state, or local government upon request in the pursuit of their official duties.		
4. WHETHER DISCLOSURE IS MANDATORY OR VOLUNTARY AND EFFECT ON INDIVIDUAL OF NOT PROVIDING INFORMATION  In the case of military personnel, the requested information is mandatory because of the need to document all active duty medical incidents in view of future rights and benefits. In the case of all other personnel/beneficiaries, the requested information is voluntary. If the requested information is not furnished, comprehensive health care may not be possible, but <b>CARE WILL NOT BE DENIED.</b>  This all inclusive Privacy Act Statement will apply to all requests for personal information made by health care treatment personnel or for medical/dental treatment purposes and will become a permanent part of your health care record.  Your signature merely acknowledges that you have been advised of the foregoing. If requested, a copy of this form will be furnished to you.		
SIGNATURE OF PATIENT OR SPONSOR Smith, Jane B 	SSN OF MEMBER OR SPONSOR 000-00-1234	DATE 20141218

DD FORM 2005, FEB 76

PREVIOUS EDITION IS OBSOLETE

Adobe Professional 7.0

**Figure 5-E. Example of DD Form 2005**

Name (Print): \_\_\_\_\_ Gender:  Male  Female Age: \_\_\_\_\_ Date of birth: \_\_\_\_/\_\_\_\_/\_\_\_\_

Are you now or have you ever been treated for any of the following:

	YES	NO	EXPLAIN				
Asthma	<input type="checkbox"/>	<input type="checkbox"/>					
Diabetes	<input type="checkbox"/>	<input type="checkbox"/>					
Hypertension (high blood pressure)	<input type="checkbox"/>	<input type="checkbox"/>					
Heart Condition	<input type="checkbox"/>	<input type="checkbox"/>					
Skipped or irregular heart beats	<input type="checkbox"/>	<input type="checkbox"/>					
Migraine Headaches	<input type="checkbox"/>	<input type="checkbox"/>					
Ear/Sinus problems/ear tubes	<input type="checkbox"/>	<input type="checkbox"/>					
Heat Injury/stroke/rhabdomyolysis	<input type="checkbox"/>	<input type="checkbox"/>					
Psychiatric/psychological and emotional difficulties	<input type="checkbox"/>	<input type="checkbox"/>					
Learning Disorders (i.e. ADHD, ADD)	<input type="checkbox"/>	<input type="checkbox"/>					
Bleeding disorders	<input type="checkbox"/>	<input type="checkbox"/>					
Fainting spells/passed out/head injury	<input type="checkbox"/>	<input type="checkbox"/>					
Thyroid Disease	<input type="checkbox"/>	<input type="checkbox"/>					
Kidney Disease	<input type="checkbox"/>	<input type="checkbox"/>					
Sickle Cell Disease	<input type="checkbox"/>	<input type="checkbox"/>					
Seizures	<input type="checkbox"/>	<input type="checkbox"/>					
Sleep disorders (i.e. sleep apnea)	<input type="checkbox"/>	<input type="checkbox"/>					
GI Problems (i.e. abdominal, digestive)	<input type="checkbox"/>	<input type="checkbox"/>					
Surgery List when and what type	<input type="checkbox"/>	<input type="checkbox"/>					
Serious injury/concussion When and what:	<input type="checkbox"/>	<input type="checkbox"/>					
Mononucleosis	<input type="checkbox"/>	<input type="checkbox"/>					
Have you ever had an injury (e.g. sprained muscle or ligament tear, or tendonitis, that caused you to miss an athletic event) If yes, circle affected area below:	<input type="checkbox"/>	<input type="checkbox"/>					
Have you had any fractured bones or dislocated joints? If yes, circle below:	<input type="checkbox"/>	<input type="checkbox"/>					
Have you had a bone or joint injury that required x-rays, MRI, CT, surgery, injections, rehabilitation, Physical Therapy, a brace, a cast, or crutches? If yes, circle below:	<input type="checkbox"/>	<input type="checkbox"/>					
Head	Neck	Shoulder	Upper Arm	Elbow	Forearm	Hand/ fingers	Chest
Upper Back	Lower Back	Hip	Thigh	Knee	Calf/ Shin	Ankle	Foot/ Toes
FEMALES ONLY							
Have you ever had a menstrual period	<input type="checkbox"/>	<input type="checkbox"/>					
How old were you when you had your first menstrual period?		AGE:					
How many periods have you had in the last 12 months		#					

Allergies:

**MEDICATIONS:**  
List all medications currently used. (If additional space is needed, please photo copy this part of the health form.)  
Inhalers and EpiPen Information must be included, even if they are for occasional or emergency use only.

Medication: \_\_\_\_\_  
Strength \_\_\_\_\_ Frequency \_\_\_\_\_  
Reason for medication: \_\_\_\_\_  
Date Started \_\_\_\_\_  
Temporary  Permanent

Medication: \_\_\_\_\_  
Strength \_\_\_\_\_ Frequency \_\_\_\_\_  
Reason for medication: \_\_\_\_\_  
Date Started \_\_\_\_\_  
Temporary  Permanent

Medication: \_\_\_\_\_  
Strength: \_\_\_\_\_ Frequency \_\_\_\_\_  
Reason for medication: \_\_\_\_\_  
Date Started \_\_\_\_\_  
Temporary  Permanent

Medication: \_\_\_\_\_  
Strength: \_\_\_\_\_ Frequency \_\_\_\_\_  
Reason for medication: \_\_\_\_\_  
Date Started \_\_\_\_\_  
Temporary  Permanent

Medication: \_\_\_\_\_  
Strength: \_\_\_\_\_ Frequency \_\_\_\_\_  
Reason for medication: \_\_\_\_\_  
Date Started \_\_\_\_\_  
Temporary  Permanent

Be sure to bring medications in the original containers and make sure they are NOT expired, including inhalers and EpiPens (approved). You SHOULD NOT STOP taking any maintenance medications. If applicable, ensure you bring two pairs of glasses and prescription.

**Figure 6-E. Safe to Train Physical**

Name (Print): \_\_\_\_\_ Date of birth: \_\_\_\_\_

Height: \_\_\_\_\_ Weight: \_\_\_\_\_ Meets Height/Weight Limits  Yes  No Pulse: \_\_\_\_\_ BP: \_\_\_\_\_ / \_\_\_\_\_ ( \_\_\_\_\_ / \_\_\_\_\_ )

Vision R 20/ \_\_\_\_\_ L 20/ \_\_\_\_\_ Corrected:  YES  NO Pupils:  EQUAL  UNEQUAL

	NORMAL	ABNORMAL	ABNORMAL FINDINGS	INITIALS*
<b>MEDICAL</b>				
Eyes	<input type="checkbox"/>	<input type="checkbox"/>		
Ears	<input type="checkbox"/>	<input type="checkbox"/>		
Nose	<input type="checkbox"/>	<input type="checkbox"/>		
Throat	<input type="checkbox"/>	<input type="checkbox"/>		
Pulses	<input type="checkbox"/>	<input type="checkbox"/>		
Lungs	<input type="checkbox"/>	<input type="checkbox"/>		
Heart	<input type="checkbox"/>	<input type="checkbox"/>		
Abdomen	<input type="checkbox"/>	<input type="checkbox"/>		
Skin	<input type="checkbox"/>	<input type="checkbox"/>		
Genitalia (males only) ***	<input type="checkbox"/>	<input type="checkbox"/>		
Inguinal Hernia	<input type="checkbox"/>	<input type="checkbox"/>		
Emotional Adjustment	<input type="checkbox"/>	<input type="checkbox"/>		
<b>MUSCULOSKELETAL</b>				
Neck	<input type="checkbox"/>	<input type="checkbox"/>		
Back	<input type="checkbox"/>	<input type="checkbox"/>		
Shoulder/arm	<input type="checkbox"/>	<input type="checkbox"/>		
Elbow/forearm	<input type="checkbox"/>	<input type="checkbox"/>		
Wrist/hand	<input type="checkbox"/>	<input type="checkbox"/>		
Hip/thigh	<input type="checkbox"/>	<input type="checkbox"/>		
Knee	<input type="checkbox"/>	<input type="checkbox"/>		
Leg/ankle	<input type="checkbox"/>	<input type="checkbox"/>		
Foot	<input type="checkbox"/>	<input type="checkbox"/>		
<b>OTHER</b>				
Glasses (contacts)	<input type="checkbox"/>	<input type="checkbox"/>		
Braces	<input type="checkbox"/>	<input type="checkbox"/>		
	<input type="checkbox"/>	<input type="checkbox"/>		

Allergies (to what agent, type of reaction, treatment)

\_\_\_\_\_

\_\_\_\_\_

\_\_\_\_\_

I certify that I have, today, reviewed the health history, examined this person and approved this individual for participation in:

- CIET Cleared without restriction
- CIET Cleared with recommendations for further evaluation or treatment for:

Not cleared for:  Physical Fitness Activities,  Specific Activities.

Reason: \_\_\_\_\_

\_\_\_\_\_

HCP Printed Name \_\_\_\_\_

MD / DO / NP / PA-C \_\_\_\_\_

Signature: \_\_\_\_\_

Address: \_\_\_\_\_

City, State, Zip \_\_\_\_\_

Office Phone: \_\_\_\_\_

Date: \_\_\_\_\_

HT/WT Standards		MAX	MAX	MAX	MAX
HT (inches)	Minimum WT	Male age 17-20	Male age 21-27	Female Age 17-20	Female Age 21-27
58	91			122	124
59	94			127	128
60	97	139	141	132	134
61	100	144	146	136	137
62	104	148	150	140	141
63	107	153	155	145	147
64	110	158	160	149	151
65	114	163	165	154	156
66	117	168	170	160	160
67	121	174	176	163	166
68	125	179	181	168	171
69	128	184	186	173	176
70	132	189	192	178	181
71	136	194	197	183	186
72	140	200	203	189	191
73	144	205	208	194	196
74	148	211	214	199	203
75	152	217	220	205	208
76	156	223	226	210	213
77	160	229	232	216	219
78	164	235	238	222	224
79	168	241	244	227	230
80	173	247	250	233	236

Figure 7-E. Safe to Train Physical (continued)



**Letter Head**

ATCC-xxDate

MEMORANDUM FOR Commandant, Cadet Summer Training, Fort Knox KY, 40121

SUBJECT: Request for Class 1A Flight Physical at the Advanced Camp (AC)

1. I am requesting a Class 1A Flight Physical for \_\_\_\_\_ (Cadet's full name) from the \_\_\_\_\_ (School Name).
2. Cadet \_\_ took the Selection Instrument for Flight Training (SIFT) on \_\_\_\_\_ (date) with a score of \_\_\_\_\_.
3. SIFT Score was entered in CCIMM Training module on \_\_\_\_\_ (date).
4. I have discussed with this Cadet his/her desires to branch aviation and based on his/her performance as the Cadet's PMS he/she has demonstrated the potential to branch aviation.
5. Point of contact is the undersigned at email and phone number.

PMS NAME  
Rank, Branch  
Title

---

**Figure 8-E. Flight Physical Request**

## APPENDIX E – Cadre In-Processing Checklists

<b>CST CADRE IN-PROCESSING CHECKLIST</b>			
CADRE NAME (RANK, LAST, FIRST, MIDDLE NAME, NAME EXTENSION):			HOST SCHOOL:
The following documents must be hand-carried by ALL personnel supporting CST. Any incomplete or incorrect packets will cause delay at in-processing and may negatively impact ability to start training.			
INITIAL	QTY	DOCUMENT	REMARKS
	1	DD Form 1610 (travel orders)	
	1	DD Form 93, Record of Emergency Data	DA Civilians
	1	DD Form 2982, Recruiter/Trainer Prohibited Activities Acknowledgement	ALL cadre-must be signed within one calendar year of scheduled CST departure date
	1	Soldier Record Brief	Military only (required for award processing)
	1	Active RSN network account	Personnel that have not signed in to CCIMM within thirty days must contact Brigade S6 to have account re-activated
	1	Valid Common Access Card (CAC) with known PIN	Fort Knox does not waiver the DoD proof of identification requirements for replacement CAC while in training. Ensure cadre travel with 2 forms of valid identification.
	Optional	Medical Records	USACC military only-All supporting document for change in medical status to update MEDPROS.
	1	Enterprise Email Account	
		OF-346 (US Gov Motor Vehicle Operator's Identification Card), DA Form 348 (Equipment Operator's Qualification Record), and 15-PAX Van Certification	As required, to drive government vehicles at CST
PMS or OIC NAME, PHONE NUMBER AND EMAIL ADDRESS:			
<p><b>All USACC Military Personnel:</b> IAW USACC directive, 100% of USACC Active Duty military personnel must complete Soldier Readiness Processing during in-processing. Fort Knox will repeat all over the age of 40 PHA labs unless complete after 1 April 2020 within a MTF. The SRP will determine the required medical and personnel stations based upon each individual's status in MEDPROs and Army field personnel information systems. All military personnel will utilize the full services available within this process to sustain individual readiness.</p>			

**Figure 9-F. Cadre In-Processing Checklist**

<b>2<sup>nd</sup> LIEUTENANT IN-PROCESSING CHECKLIST</b>		
<b>Name:</b>		
<b>Phone/email address:</b>		
<b>Active Duty Date:</b>		
<b>School:</b>		
<b>CST Assignment:</b>		
<b>CST Report Date:</b>	<b>CST Depart Date:</b>	<b>BOLC Report Date:</b>
<b>Required CST Documents: The below documents must be hand-carried to CST G1 at Fort Knox for onboarding</b>		
<b>ITEM #</b>	<b>DESCRIPTION</b>	<b>CHECK</b>
1	One complete sets of orders and approved <a href="#">1610s</a> to include amendments (for CST and BOLC)	
2	<a href="#">W4</a> Employee Withholding Allowance (current version)	
3	<a href="#">DD Form 2058</a> Statement of Legal Residence (most recent version)	
4	<a href="#">DD Form 2058-1</a> State Tax Exemption (if applicable) (most recent version)	
5	<a href="#">DA Form 5960</a> (BAH), Need copy of marriage/birth certificate and copy of court order for child support, if applicable (most recent version)	
6	Uniform Allowance Statement (Figure 13-F)	
7	<a href="#">DA Form 3685</a> Pay Election (most recent version)	
8	Faststart Direct Deposit form; FMS Form 2231, dtd 11-92 or <a href="#">SF 1199</a> Direct Deposit with a voided check (most recent version signed by the organization) SF 1199 must be signed by a bank representative to be accepted by finance	
9	DD Form 2560 Advanced Pay Certification/Authorization	
10	<a href="#">DD 93</a> Emergency Data (copy) (most recent version)	
11	<a href="#">SGLV 8286</a> Servicemen's Group Life Ins Election and Cert.	
12	<a href="#">NGB Form 22</a> , <a href="#">DD Form 214</a> and <a href="#">Discharge Order</a> if applicable	
1	Military Personnel Record	
2	<a href="#">DA 31</a> (If selected for Immediate Active Duty, leave form must be effective the date of commission (or depart from school) through CST report date.	
3	<a href="#">DA 71</a> (Oath of Office)	
4	Medical Record and commissioning physical	
5	Immunization Record	
*****	2LT MUST BE INSTRUCTED NOT TO USE THEIR CAC TO ACCESS FORT KNOX-OR IT MAY BE CONFISCATED. They must use alternate photo ID to obtain a pass at Fort Knox Visitor's Center.	

**Figure 10-F. 2LT In-Processing Checklist**

DATA REQUIRED BY THE PRIVACY ACT 1974			
<p>1. Authority: Section 3687, Title 10, U.S. Code</p> <p>2. Principal Purpose(s): Provides a basis for reimbursement of an individual's uniform allowance upon entry on active duty:</p> <p>3. Routine Use: Establishment of individual's entitlement to the allowance and ultimately to pay him/her this entitlement.</p> <p>4. Mandatory or voluntary disclosure and effect on the individual not providing information: Mandatory: noncompliance may result in delay or denial of payment of uniform allowance</p>			
UNIFORM ALLOWANCE STATEMENT			
<p>I request reimbursement for uniform allowance as provided in Chapter XXX, DODFMR Volume 7A. Specifically: (Check the block on which entitlement is based.)</p> <p style="text-align: center;"> <span style="margin-right: 150px;">Initial Uniform Allowance-Completion of 14 days AD or ADT</span> <span style="border: 1px solid black; border-radius: 50%; padding: 2px;">Initial Uniform Allowance AD in excess of 90 days</span> </p> <p style="text-align: center;"> <span style="border: 1px solid black; border-radius: 50%; padding: 2px;">Active Duty Uniform Allowance</span> </p>			
SECTION I-INITIAL UNIFORM ALLOWANCE-Completion of 14 days AD or ADT			
Enter inclusive dates during which not less than 14 days of AD or ADT were performed:			
From:		To:	
SECTION II-INITIAL UNIFORM ALLOWANCE-AD in excess of 90 days			
1. Status immediately prior to entry on active duty:			
CADET			
2. Date of final type physical examination:			
3. Date reported for AD in excess of 90 days:			
4. Cite complete authority (Issuing HQ date of orders, etc):			
HQ, USACC, FIKY, ORDERS #		DATE:	
SECTION III-ACTIVE DUTY UNIFORM ALLOWANCE			
1. Date of final type physical examination:		2. Date reported for AD for an indefinite period in excess of 90 days:	3. Cite complete authority (Issuing HQ, date of orders, etc):
			HQ, USACC, FIKY, ORDERS # DATE:
Signature		Date	
Printed Name		SSN	

Updated  
January 2006

FIGURE 11-F (2LT UNIFORM ALLOWANCE STATEMENT)

USACC CIRCULAR 145-5, 12 October 2021

## **APPENDIX F – POV Storage SOP**

### **a. Responsibilities.**

(1) The TF Warrior and Leader have overall responsibility for the Cadet POV storage area.

(2) Regimental Cadre. The Regiment will execute this SOP, ensuring only authorized Cadets use the POV Storage Area, accessible through coordination with CST Transportation and ensure only authorized POVs are placed in the POV Storage Lot. The Regiment will coordinate with the CST Transportation cell for access to the POV storage lot and ensure HFL Form 45 and FKKY Form 4860 are used to inventory and document the condition of incoming and outgoing vehicles. A logbook, containing all forms, will be maintained in the Regimental TOC. Vehicle keys will be retained and secured in the Regimental TOC.

(3) Cadet. Each Cadet using the POV Storage Lot will ensure the POV has proper state registration, a current driver's license, and vehicle insurance. Cadets will complete HFL Form 45 and ensure only authorized items are stored in the vehicle. Cadets must remove POVs from the lot within 48 hours from CST completion or from the time the Cadet is dismissed from CST.

### **b. Operating Procedures.**

#### **(1) Vehicle In-Processing.**

(a) Upon arrival at CST, Cadets with POVs will report to the Regimental in-processing area and notify the Regimental cadre of the need to place POV in the POV Storage Area.

(b) The Regimental cadre will verify the vehicle has a valid state registration and current insurance coverage and will verify the Cadet has a valid driver's license.

(c) The Cadet will complete HFL Form 45 and POV Storage Agreement (Fig 13-G and 14-G). The Cadet will initial the top right of HFL Form 45 indicating he or she understands the conditions for the use of the Cadet POV Storage Lot. A copy of HFL

USACC CIRCULAR 145-5, 12 October 2021

Form 45 will be placed in the vehicle, a copy will be given to the office of the TF Warrior or Leader, and the original will be kept with the Regimental logbook.

(d) A joint inspection will be conducted by the Cadet owner of the POV and a representative from the Regimental cadre to verify all information indicated on HFL Form 45 is correct. The inspecting cadre will sign, date and print their name on the bottom of the form to indicate the completion of the inspection.

(e) In extreme circumstances and approved by the TF Warrior and Leader, the Cadet may allow a personal representative to pick up the POV on behalf of the Cadet. The Cadet will, prior to reporting to CST, obtain a notarized Special Power of Attorney (POA). The POA should specifically refer to the Make, Model, Year, Color, VIN as stated on the HFL Form 45 the Cadet completed. The HFL Form 45, Section II, should specifically refer to the POA. A copy of the POA will be attached to the HFL Form 45. The Cadet will give the original POA to his or her representative.

(f) FKKY 4860 (POV Inspection Checklist, Fig 15-G) will be filled out by the Regimental cadre Representative and placed in the Cadet POV logbook.

(g) The CST Cadet POV Storage Lot In/Out-Processing Inspection Checklist will be filled out and maintained in the Cadet POV Storage logbook and maintained at the Regimental Operations Center.

(h) The POV Storage Agreement will be filled out and signed by the Regimental cadre conducting the inspection and by the Cadet.

(2) Disposition of the POV.

(a) Remove all personal property from the POV - Loss of personal items left in vehicle may not be compensable by the government. All personal and military items such as clothes, tool, CDs, etc, should be removed and stored with your personal property.

(b) Identify a point of contact in case of emergency regarding the POV - In case there is an emergency concerning the POV, it will be the necessary for the Regimental cadre to have the name, unit, address, and telephone number of a POC.

(c) Make copies of the vehicle's registration, the insurance card, and the Cadet's driver's license. The POV registration and proof of insurance are necessary for the Cadet to store the POV in the POV Storage Lot. Copies of these three (3) documents will be included in the packet.

(d) Ensure the vehicle inspection form (FKKY 4860) is properly filled out and correctly reflects pre-existing damage to the POV. Ensure inspector correctly annotates the condition of the vehicle prior to placement in POV storage.

(e) Provide copies of the following: One (1) copy of POA (if required), three (3) copies of the registration, and three (3) copies of proof of current insurance.

(f) Two (2) copies of the entire packet will be reproduced. The original will remain with the Cadet keys in the Regimental Logbook, one (1) copy will be placed in the Cadet's POV, and one (1) copy will go in the office of the TF Warrior or Leader Logbook.



(g) Vehicle Keys will be secured in the Regimental Operations Center.

(3) Vehicle Out-processing.

(a) Within 48 hours after the Cadet completes or has been dismissed from CST, the Cadet will remove their POV from the POV Storage Facility. The chain of command will be notified if the Cadet fails to remove the POV within 48 hours. If no action is taken within five (5) days, the vehicle will be considered abandoned. The Military Police will be notified to remove it from the installation.

(b) A Regimental Representative will coordinate with the TF Warrior or Leader Operations Cell, building 5931, for removal of Cadet vehicles from the POV storage lot. The Regimental cadre will out-process stored POVs. The copy of HFL Form 45 placed on the dashboard during in-processing will be returned and placed in the logbook along with the original. The original copy will be signed and dated by the owner or authorized individual upon leaving the area and turned into the TF Warrior or Leader Operations Cell for retention until the end of CST.

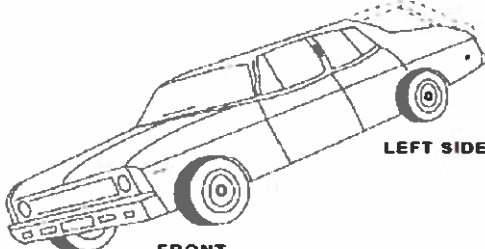
# DISPOSITION OF POV DURING OWNER'S ABSENCE

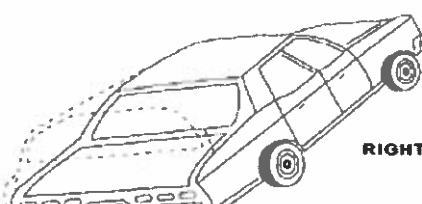
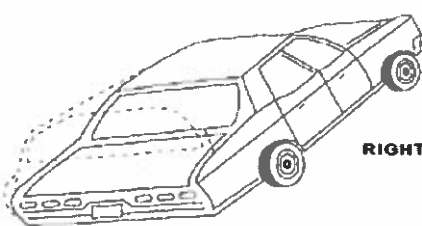
<b>DISPOSITION OF POV DURING OWNER'S ABSENCE</b>					
For use of this form see I Corps and Fort Lewis R3OP					
PRIVACY ACT STATEMENT					
<p><b>AUTHORITY:</b> Title 5 U.S.C. 301, Executive Order 9397.</p> <p><b>PRINCIPAL PURPOSE(S):</b> To administer programs devoted to the well-being of Army personnel and other authorized users and specifically to identify individual owners and provide contact information concerning personally owned vehicle(s) stored in the vehicle storage lots for personnel who have deployed.</p> <p><b>ROUTING USES:</b> These records or information contained therein may specifically be disclosed outside the DoD as a routine use pursuant to 5 U.S.C. 552a(a)(3).</p> <p><b>DISCLOSURE:</b> Disclosure of information is voluntary. Failure to provide the requested information will result in the denial of use of the long-term POV storage lots.</p>					
INSTRUCTIONS					
(All Required Information will be Printed in Ink)					
<p>1. Sections 1 - May be completed in advance, odometer block will be completed upon turn-in.</p> <p>2. Distribution of copies:</p> <p style="margin-left: 20px;">a. Copy No. 1 will remain on file with the the Soldier's unit POV Representative.</p> <p style="margin-left: 20px;">b. Copy No. 2 will be given to Soldier turning in the POV.</p> <p style="margin-left: 20px;">c. Copy No. 3 will remain in the vehicle while in storage and placed on dash board face down.</p> <p>Temporary POV parking is made available, without gratuity, while owner is absent due to military requirements. Valuables will be removed from POV. POV will be picked up within 60 days after deployment or disposed of IAW existing DOD Directives and/or Regulations. Owner's initials: _____</p>					
SECTION I PRE-DEPLOYMENT					
PRINT OWNER'S NAME (Last, First, MI)			RANK	SSN (LAST FOUR)	ORGANIZATION
MAKE	MODEL	YEAR	COLOR	LICENSE No.	STATE
VIN NUMBER			POST DECAL	ODOMETER	
SIGNATURE OF OWNER			DATE		
NAME OF UNIT INSPECTOR		GRADE/RANK	SIGNATURE OF UNIT INSPECTOR		DATE
<div style="display: flex; justify-content: space-around; align-items: center;"> <div style="text-align: center;">  <p><b>FRONT</b></p> </div> <div style="text-align: center;">  <p><b>LEFT SIDE</b></p> </div> <div style="text-align: center;">  <p><b>RIGHT SIDE</b></p> </div> <div style="text-align: center;">  <p><b>BACK</b></p> </div> </div>					
DESCRIPTION OF DAMAGE PRIOR TO DEPLOYMENT					

HFL FORM 45, NOV 2008  
DPTMS

PREVIOUS EDITIONS ARE OBSOLETE

Page 1 of 2  
PL PE V1.02

**Figure 11-G. Cadet POV Registration Form HFL Form 45 (Front)**

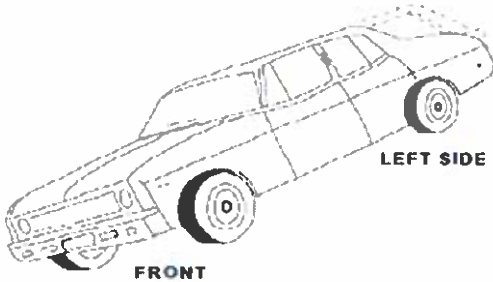
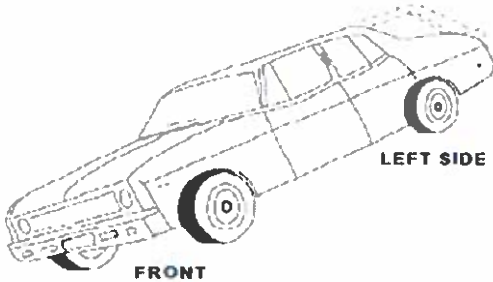
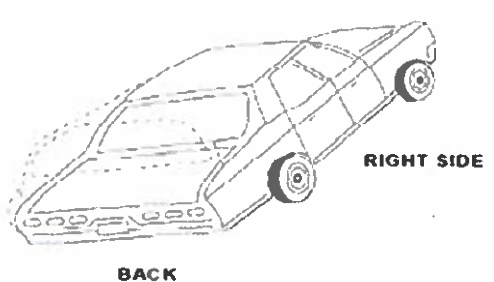
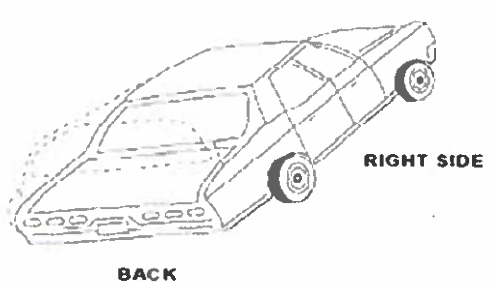

SECTION II			
<p>THE FOLLOWING INFORMATION IS TO BE WRITTEN ON THE BACKSIDE OF THIS FORM AND PLACED FACE UP ON DASH BOARD.</p> <p>SOLDIER'S NAME: _____</p> <p>ORGANIZATION: _____</p> <p>UNIT CONTACT NUMBER: _____</p>			
SECTION III - POST DEPLOYMENT			
PRINT OWNER'S NAME (Last, First, MI)	RANK	SSN (LAST FOUR)	ORGANIZATION
SIGNATURE OF OWNER		DATE	
NAME OF UNIT INSPECTOR	GRADE/RANK	SIGNATURE OF UNIT INSPECTOR	DATE
POV IS IN THE SAME CONDITION PRIOR TO DEPLOYMENT <input type="checkbox"/> YES <input type="checkbox"/> NO (If no, please specify)			
<p><b>CONDITION OF POV (Record marks, exposed metal and/or structural damage)</b></p> <div style="display: flex; justify-content: space-around; align-items: center;"> <div style="text-align: center;">  <p>FRONT</p> </div> <div style="text-align: center;">  <p>LEFT SIDE</p> </div> <div style="text-align: center;">  <p>BACK</p> </div> <div style="text-align: center;">  <p>RIGHT SIDE</p> </div> </div>			
DESCRIPTION OF DAMAGE UPON RETURN FROM DEPLOYMENT			

HFL FORM 45, NOV 2008  
OPTMS

Page 2 of 2  
FL PG #102

**Figure 12-G. Cadet POV Registration Form HFL Form 45 (Back)**

POV INSPECTION CHECKLIST			
For use of this form, see F-101 Knox Reg 300-10			
OWNER/OPERATOR'S NAME: _____			
UNIT: _____	DUTY PHONE: _____		
YEAR/TYPE VEHICLE: _____	MILEAGE: _____		
ITEM	SAT	UNSAT	REMARKS
1. LIGHTS			
a. Headlights	<input type="checkbox"/>	<input type="checkbox"/>	_____
b. Tailights	<input type="checkbox"/>	<input type="checkbox"/>	_____
c. Backing lights	<input type="checkbox"/>	<input type="checkbox"/>	_____
d. Emergency flashers	<input type="checkbox"/>	<input type="checkbox"/>	_____
e. Turn signal indicators	<input type="checkbox"/>	<input type="checkbox"/>	_____
f. Brake lights	<input type="checkbox"/>	<input type="checkbox"/>	_____
2. GLASS			
a. Windshield	<input type="checkbox"/>	<input type="checkbox"/>	_____
b. Rear window	<input type="checkbox"/>	<input type="checkbox"/>	_____
c. Rear-view mirror	<input type="checkbox"/>	<input type="checkbox"/>	_____
3. EXHAUST SYSTEM	<input type="checkbox"/>	<input type="checkbox"/>	_____
4. WINDSHIELD WIPERS/WASHERS	<input type="checkbox"/>	<input type="checkbox"/>	_____
5. HORN	<input type="checkbox"/>	<input type="checkbox"/>	_____
6. STEERING SYSTEM	<input type="checkbox"/>	<input type="checkbox"/>	_____
7. BRAKE SYSTEM			
a. Driving brakes	<input type="checkbox"/>	<input type="checkbox"/>	_____
b. Emergency brake	<input type="checkbox"/>	<input type="checkbox"/>	_____
8. TIRES (including spare and changing equipment)	<input type="checkbox"/>	<input type="checkbox"/>	_____
9. SUSPENSION SYSTEM/SHOCK ABSORBERS/SPRINGS	<input type="checkbox"/>	<input type="checkbox"/>	_____
OVERALL RATING	<input type="checkbox"/>	<input type="checkbox"/>	_____
COMMENTS			

FK FORM 4860, AUG 20 92

PREVIOUS EDITIONS ARE OBSOLETE

Page 1 of 2  
FK LP 10 20 92

**Figure 13-G. Cadet POV Inspection Form FKKY Form 4860**

(c) Cadet POV Storage Checklist:

- CLEAN YOUR POV INSIDE AND OUT**
  - This makes the inspection of your vehicle easier and eliminates the potential for **Rodents** entering your vehicle or accumulation of odor because of food left inside the vehicle.
  
- REMOVE ALL PERSONAL PROPERTY FROM YOUR POV**

USACC CIRCULAR 145-5, 12 October 2021

- Loss of personal property left in your vehicle may not be compensable by the government. All personal property such as shoes, clothes, tools, CD's, CD cases, tapes, car seats, TA-50, paperwork, etc should be removed and stored with your **Personal Property**.
  
- REMOVE ALL PORTABLE ACCESSORIES FROM YOUR POV**
  - Remove portable radios, tape players, CD players, DVD players, speakers, amplifiers, etc. If these items can be removed from your vehicle, it is **HIGHLY RECOMMENDED** they be removed.
  
- MAKE SURE ALL FLUID LEVELS ARE AT THE PROPER LEVEL**
  - Having all fluid levels in your vehicle at the proper levels prior to storage will decrease your chances of having any problems with your vehicle when you pick it up.
  
- HAVING PROPER TIRE AIR PRESSURE IN ALL 4 TIRES**
  - It is **highly recommended** you have the proper tire air pressure in all tires during storage. This will help keep your tires in good condition and from going flat during storage.
  
- DOCUMENTS REQUIRED TO STORE YOUR POV?**
  - HFL 45 and FKKY 4860 Completed by cadre.
  - Proof of Insurance and Registration.
  - I.D. Card.
  - Power of Attorney for pick up of vehicle (if applicable)

**Figure 14-G. Cadet POV Storage Checklist**

## APPENDIX G – Remediation for Advanced Camp Credit



DEPARTMENT OF THE ARMY  
UNITED STATES ARMY CADET COMMAND  
UNIVERSITY  
ADDRESS

REPLY TO  
ATTENTION OF:

ATCC-OFFICE SYMBOL

DATE

MEMORANDUM THRU Commander, X Brigade, ATTN; BRIGADE HQ ADDRESS

FOR Commander, HQ, USA Cadet Command, ATTN: G37—Training Division, (Cadet Summer Training Division), 5931 Quinn Hall Building, Fort Knox, KY 40121

SUBJECT: Remediation for Advanced Camp Credit for Cadet NAME, CADET ID #

1. Cadet NAME attended Cadet Summer Training (CST) 20XX from DD MMM to DD MMM YYYY. Cadet NAME was assigned to # Regiment, X Company. Cadet NAME failed to meet the EVENT Qualification requirements.

2. The Advanced Camp Leader Development Review Board determined that Cadet NAME will complete CST without credit and return to the University for remediation of EVENT. Upon remediation, credit for camp may be awarded. On DD MMM YYYY, Cadet NAME successfully completed the EVENT Remediation (include details (time, score, outcome) and enclosure any required score cards)

3. I recommend, effective immediately that Cadet FULL NAME be given full camp credit.

4. The point of contact for this memorandum is POC NAME at (XXX) XXX-XXXX or email@mail.mil.

Encl  
(ALL SUPPORTING DOCS)

PMS Signature Block

Professor of Military Science

USACC CIRCULAR 145-5, 12 October 2021